

Manuale per la ricostruzione di Onna



prodotto da: Innsbruck Universität, Fakultät Architektur - Fachbereich Baugeschichte
Univ. Prof. Dr. Wittfrida Mitterer, Univ. Prof. Horst Hambrusch

Abaco dei dettagli costruttivi

UNIVERSITÀ DI INNSBRUCK
FACOLTÀ D'ARCHITETTURA

GRUPPO DI LAVORO

Univ. Prof. Horst Hambrusch, Univ. Doz. Dr. Wittfrida Mitterer,
Univ. Ass. DI Bea Fröis, Univ. Prof. Joachim Moroder

David Barlini, Daniela Beck, DI Martin Lochmann, Christina Passler, Ales-
sandro Pisoni, Bernhard Prem, Tobias Schöpf



MAGGIO 2010

SOMMARIO

Introduzione.....	4
Topografia.....	5
Spazi pubblici.....	6
Struttura architettonica e muri a margine del territorio rurale.....	7
Muri e cancelli.....	11
Fontane e abbeveratoi.....	17
Archi.....	27
Portoni.....	36
Finestre.....	46
Scala esterna.....	54
Tetti.....	59
Camini.....	63
Muratura.....	65
Cordolo.....	67
Soglia.....	68
Deposito lapideo.....	69
Forno.....	70
Indice bibliografico e delle foto.....	72

INTRODUZIONE

Alla base della ricostruzione di Onna vi sono gli elementi compositivi tipologici, caratteristici e identificativi del patrimonio culturale locale, a partire dalla topografia urbanistica del territorio, fino al singolo nucleo abitato.

L'abaco analizza e rappresenta questi dettagli costruttivi, comprendendone la rete viaria, la rete idrica con fontane e punti acqua, strade e piazze caratteristiche. La tipologia costruttiva di muri, portoni, archi e porticati costituiscono nel loro insieme i luoghi della memoria collettiva, fondando le profonde radici del luogo.

L'insieme degli spazi pubblici e il linguaggio delle singole forme degli elementi costruttivi sono, in quanto parte integrante dello sviluppo delle facciate, gli elementi basilari compositivi dell'intero paese. Il luogo può così essere rinnovato, salvaguardato e migliorato solo nel suo insieme: la ricostruzione non è infatti la somma di interventi singoli ma un'opera collettiva. L'agire comune e partecipato, attraverso un coordinamento unico, aumentano l'efficienza globale, minimizzando però la mole di

lavoro materiale, formale e burocratico.

Attraverso la realizzazione di progetti pilota i criteri compositivi dell'architettura rurale proposti devono rientrare nell'immaginario collettivo. Così la salvaguardia in situ di elementi edilizi originali e di strutture collegate sono indispensabili per l'identificazione degli abitanti con il loro paese e la loro storia. La realizzazione diretta e attenta dei singoli elementi edilizi consentono la varietà dell'immagine originaria, rifondando il DNA tipico di Onna.

L'abaco vuole essere quindi un riferimento per una migliore gestione partecipata del progetto di ricostruzione. La documentazione raccolta costituisce la base per un "Libretto degli oneri e doveri", in cui sono contenuti: le misure, i consigli tecnici e concreti, le soluzioni proposte, nonché la consulenza e i metodi di conciliazione per la cooperazione tra gli abitanti e i tecnici, i politici e l'amministrazione.

Horst Hambrusch / Wittl Mitterer

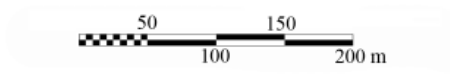
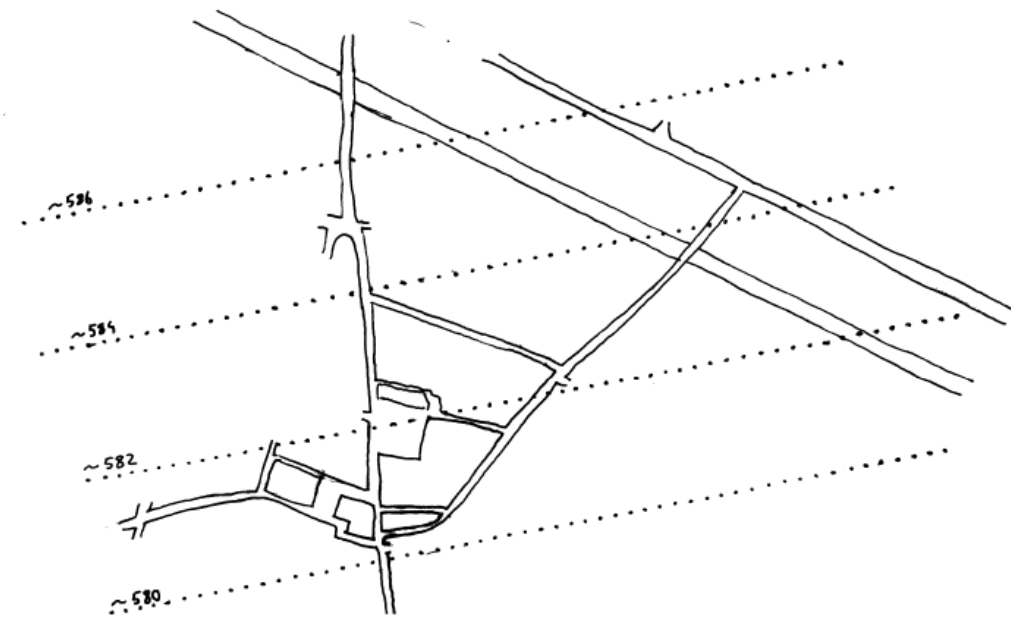
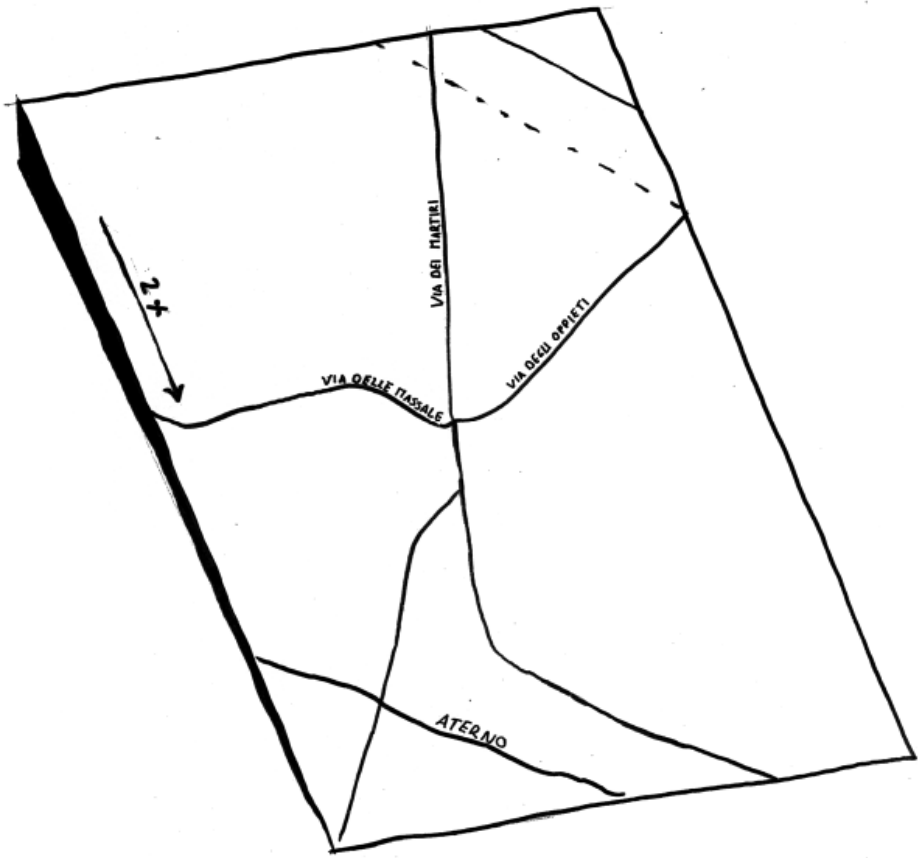

TOPOGRAFIA

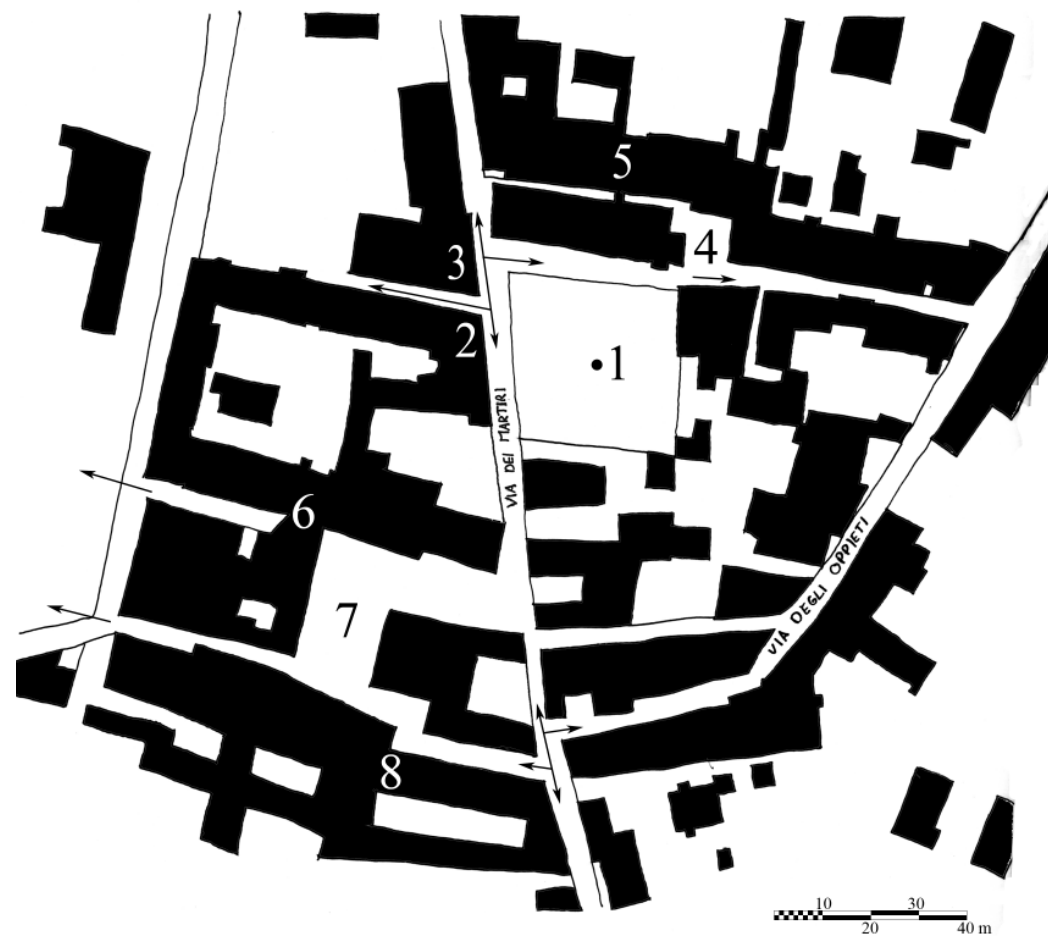

1 Villa Comunale
 2 Forno
 3 Bed & Breakfast
 4 Piazzetta del Panettiere

5 Arco, Via della Colonna
 6 Arco, Via dell'Arco
 7 Piazza Umberto I
 8 Arco Ciancone, Via della Prepositura

GLI SPAZI PUBBLICI



PLASTICO IN TERRACOTTA
STRUTTURA ARCHITETTONICA



STRUTTURA ARCHITETTONICA E MURI
A MARGINE DEL TERRITORIO RURALE



PROSPETTI SPAZI PUBBLICI

INTERSEZIONE A FORMA DI "T"



PROSPETTI SPAZI PUBBLICI

INTERSEZIONE A FORMA DI "T"



MURI ESTERNI



PORTALI E CANCELLI

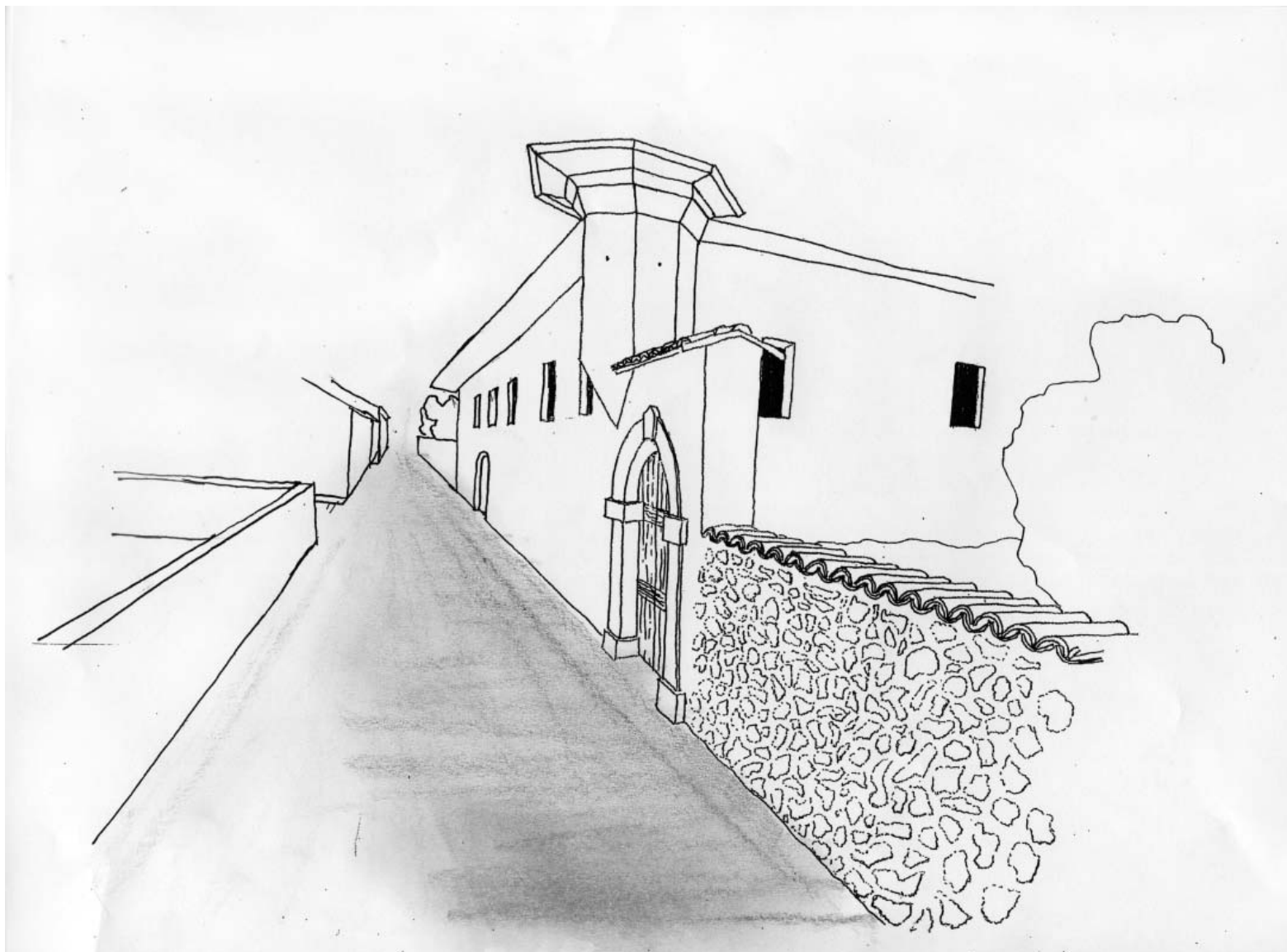

VILLA ALFIERI

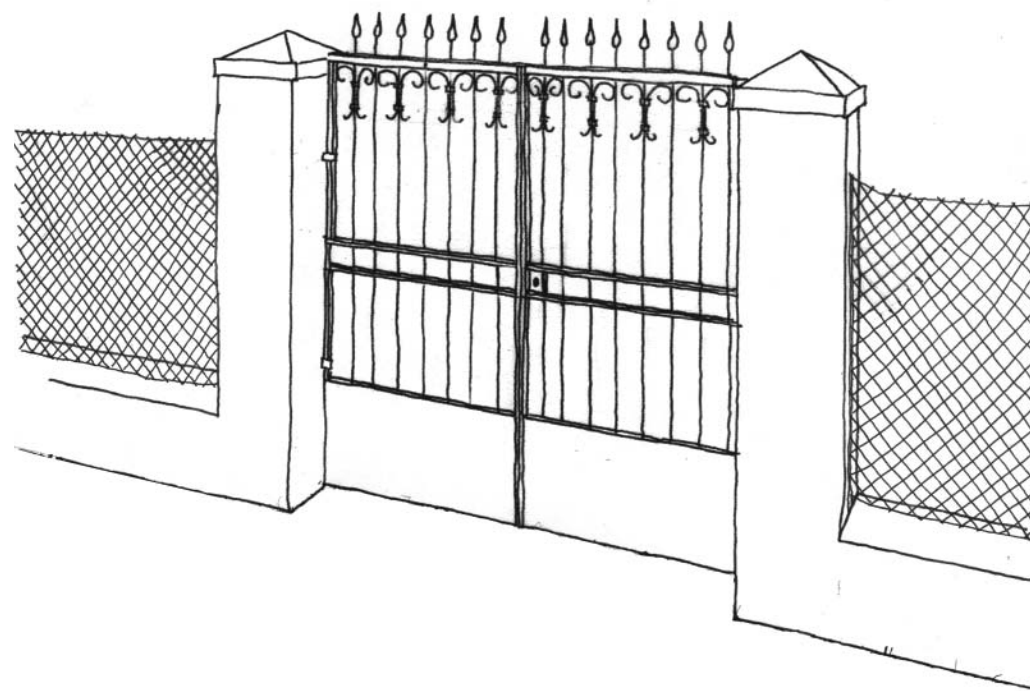

ENTRATA CENTRO ANZIANI

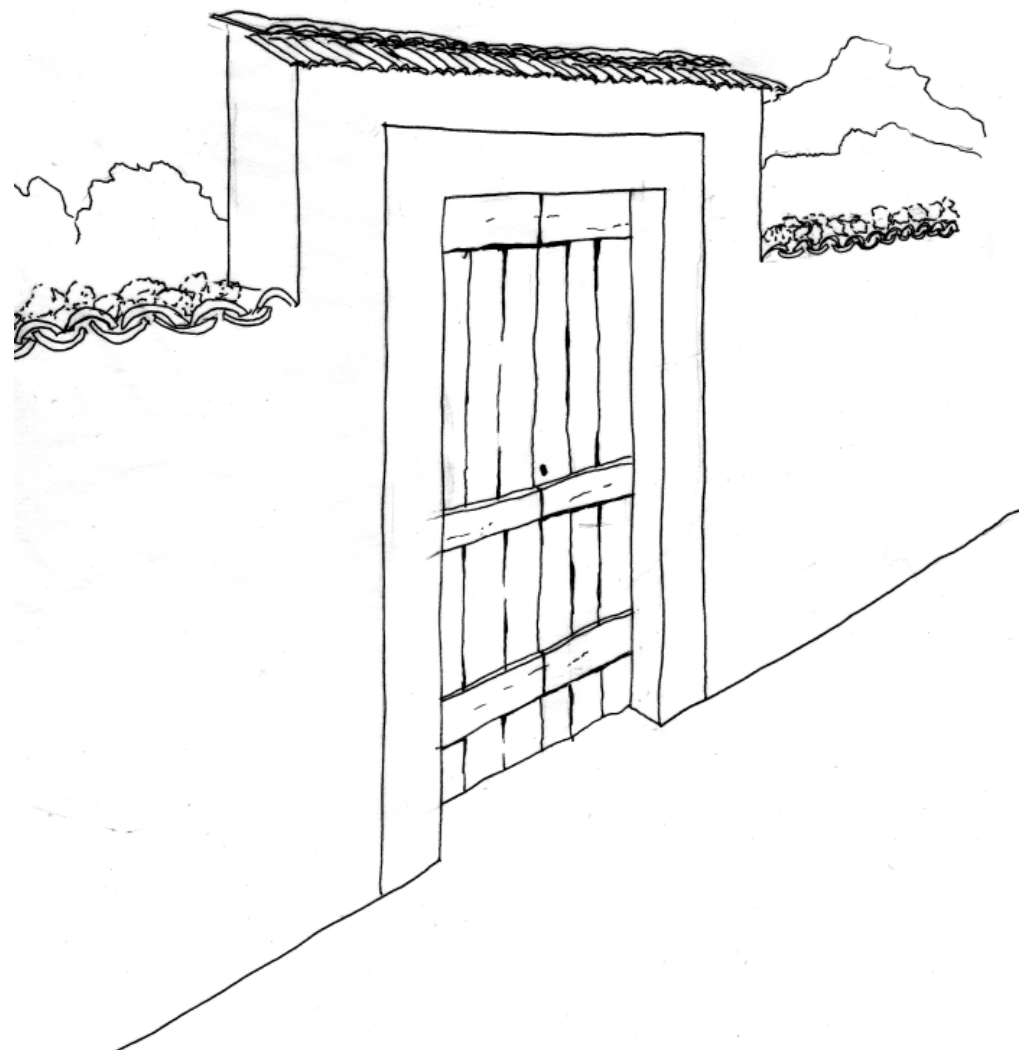

VIA DEI MARTIRI

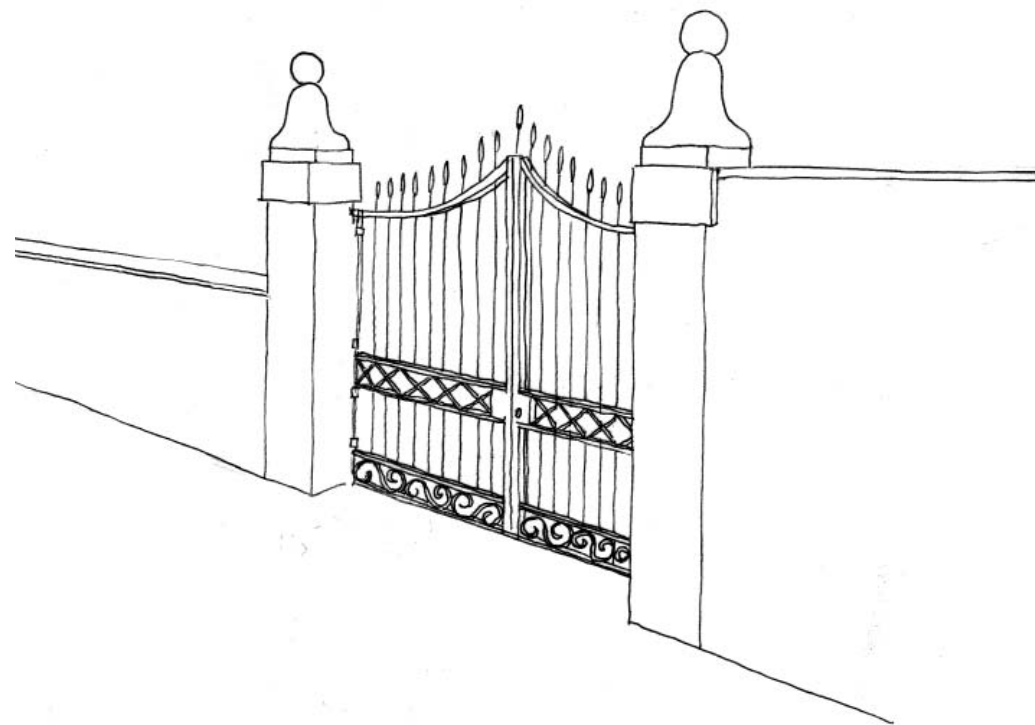

VIA DEGLI OPPIETI



FONTANE E ABBERVERATOI



PUNTI D'ACQUA

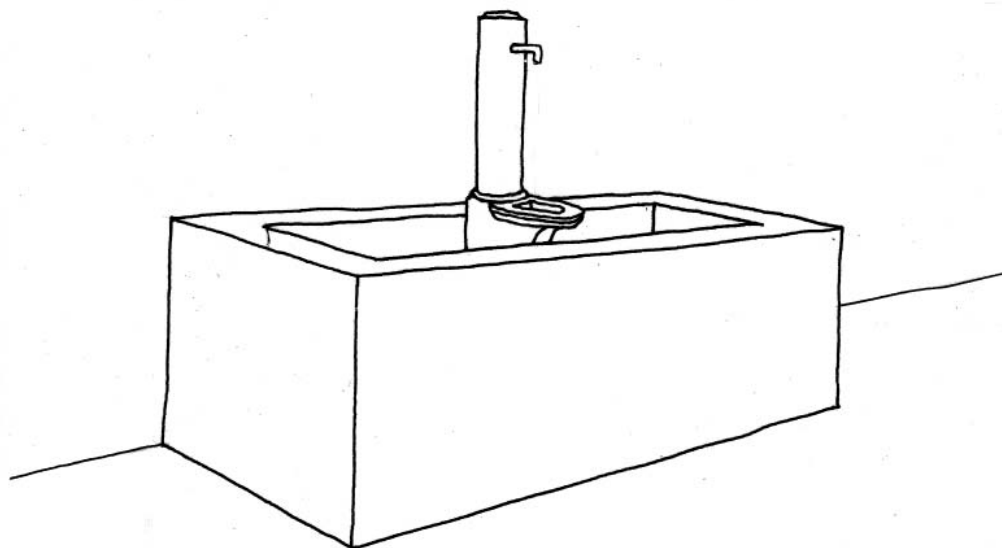

CASA ONNA

N. 1

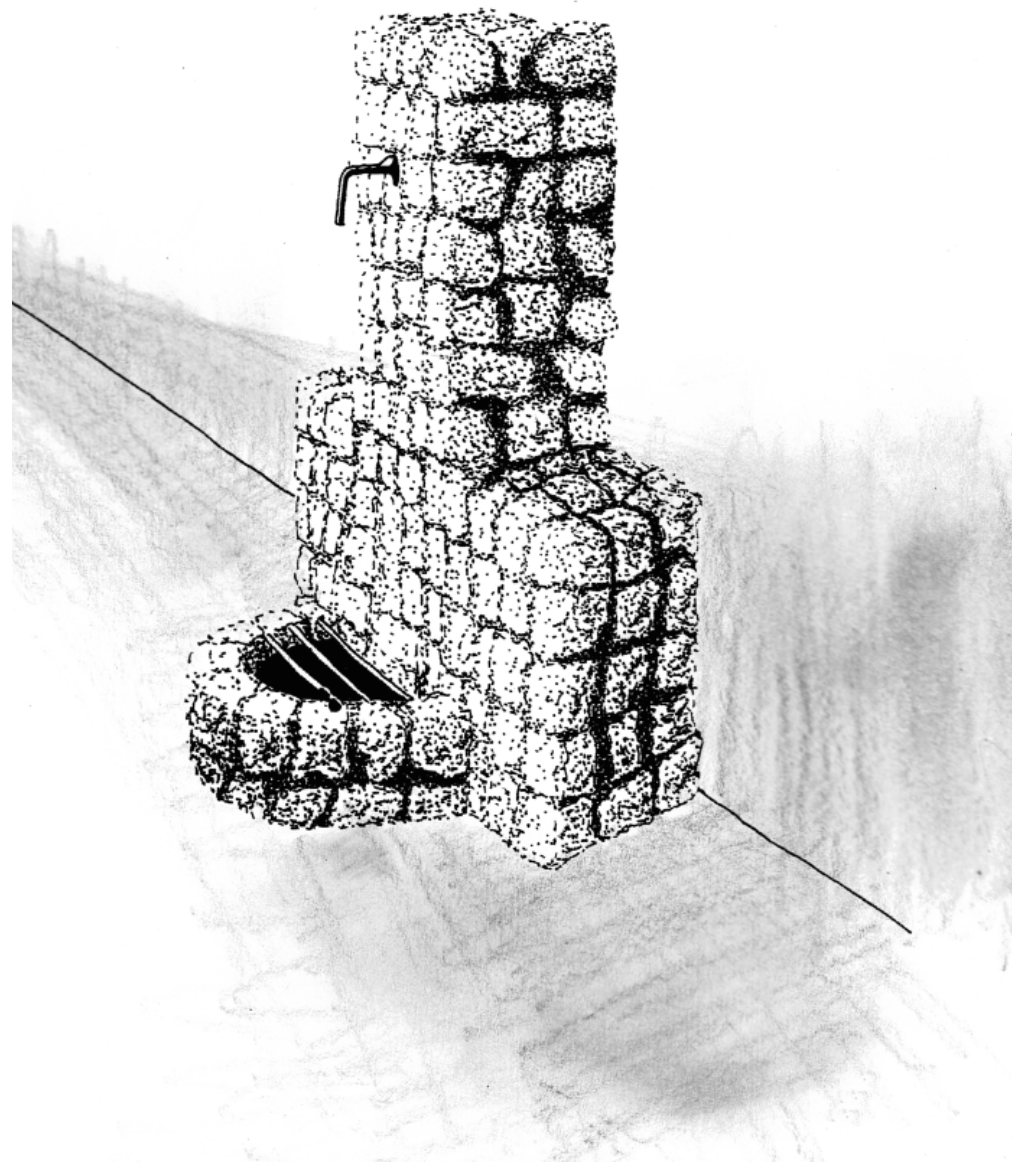

VIA DELLE MASSALE

N. 2

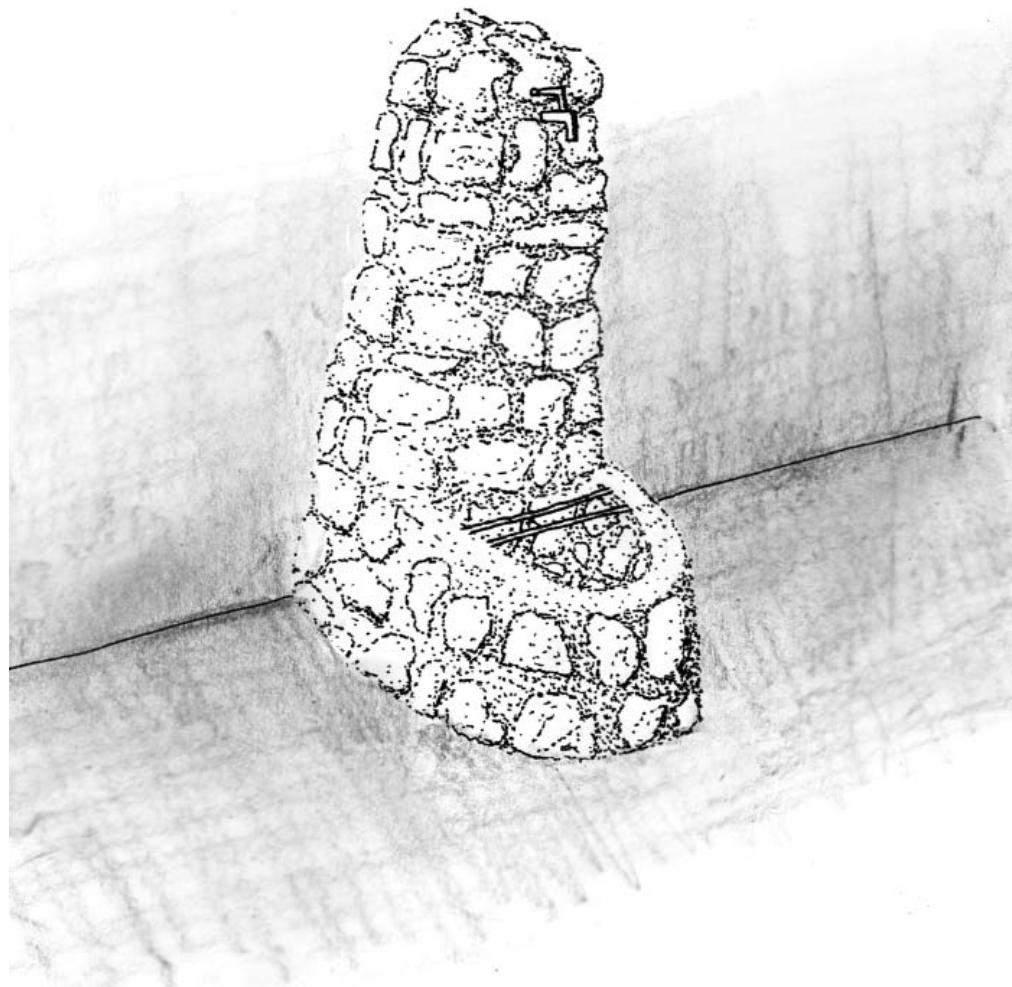

VIA DELLA MASSALA - VILLA COMUNALE

N. 3, N. 9

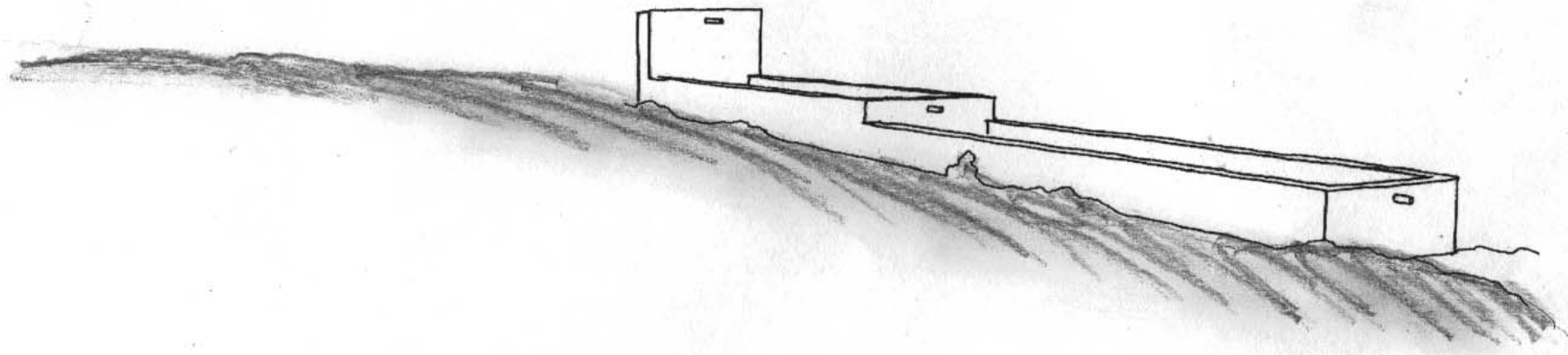

ABBEVERATOIO

N. 4

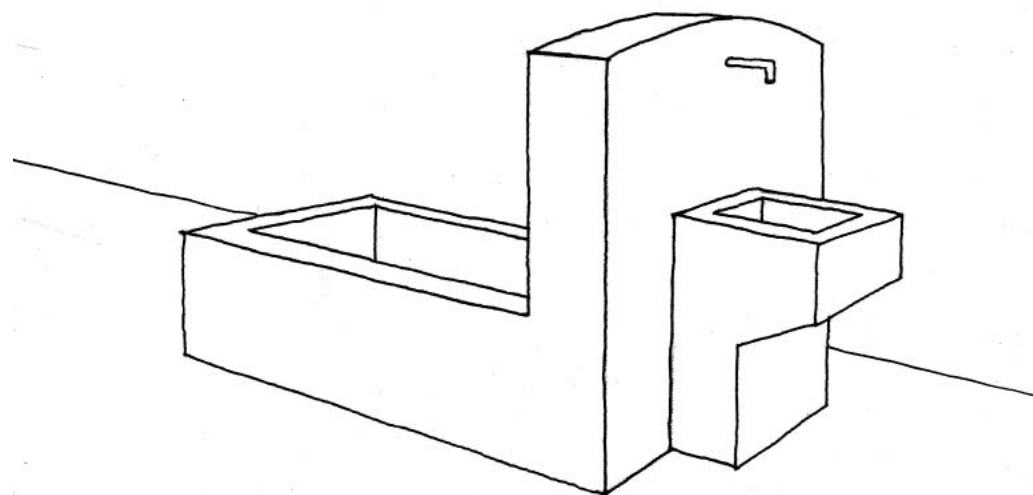

VIA DEI MARTIRI

N. 6

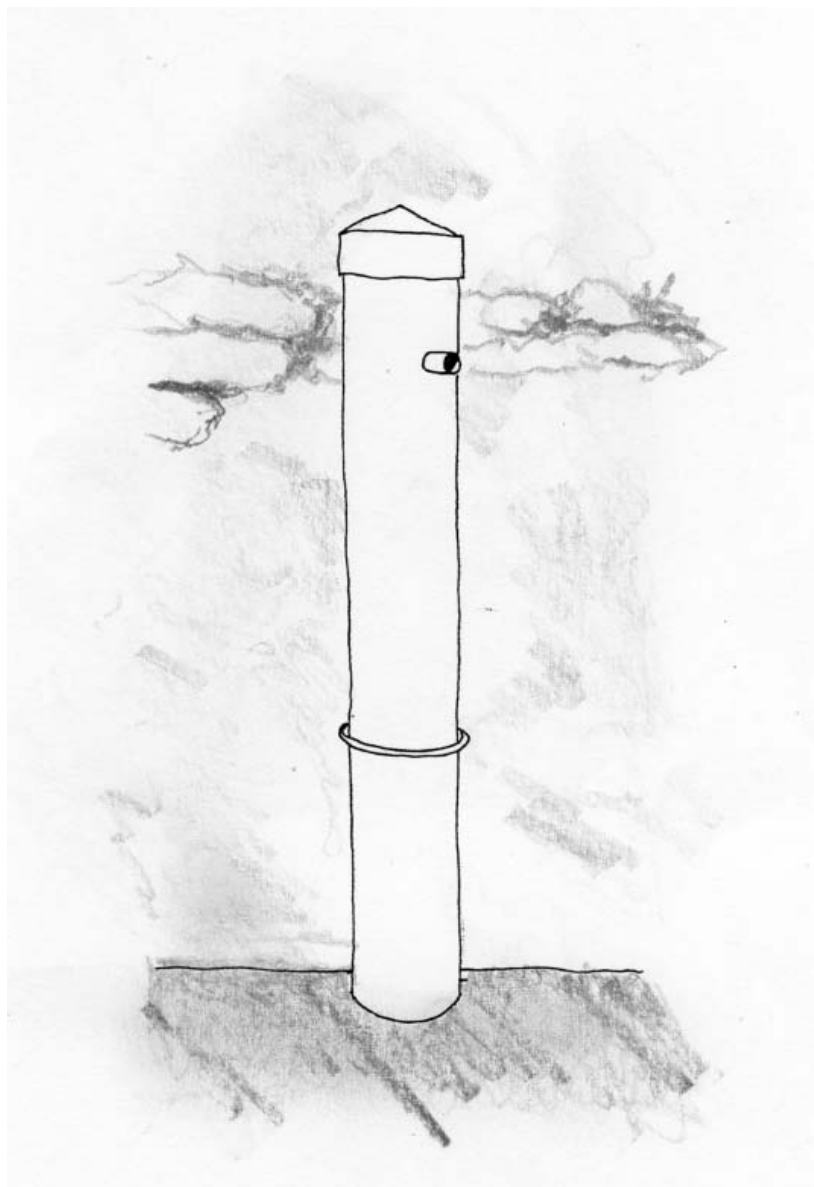

VIA DEGLI OPPIETI

N. 8

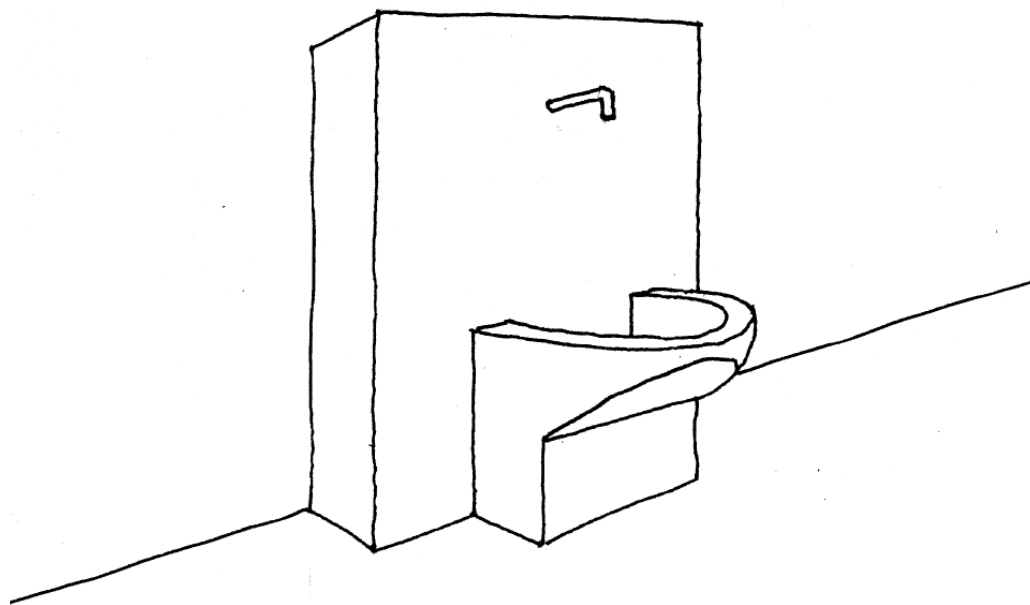

VIA DEGLI OPPIETI

N. 10

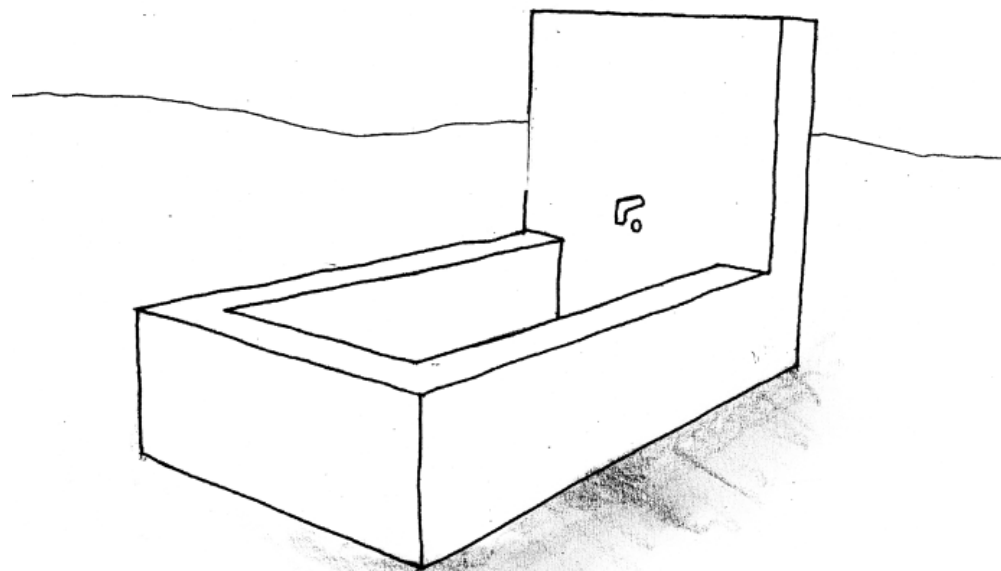

ABBEVERATOIO

N. 11



VIA DELL'ARCO

ARCO, VISTA PIAZZA UMBERTO I



ARCO, PIAZZA UMBERTO I

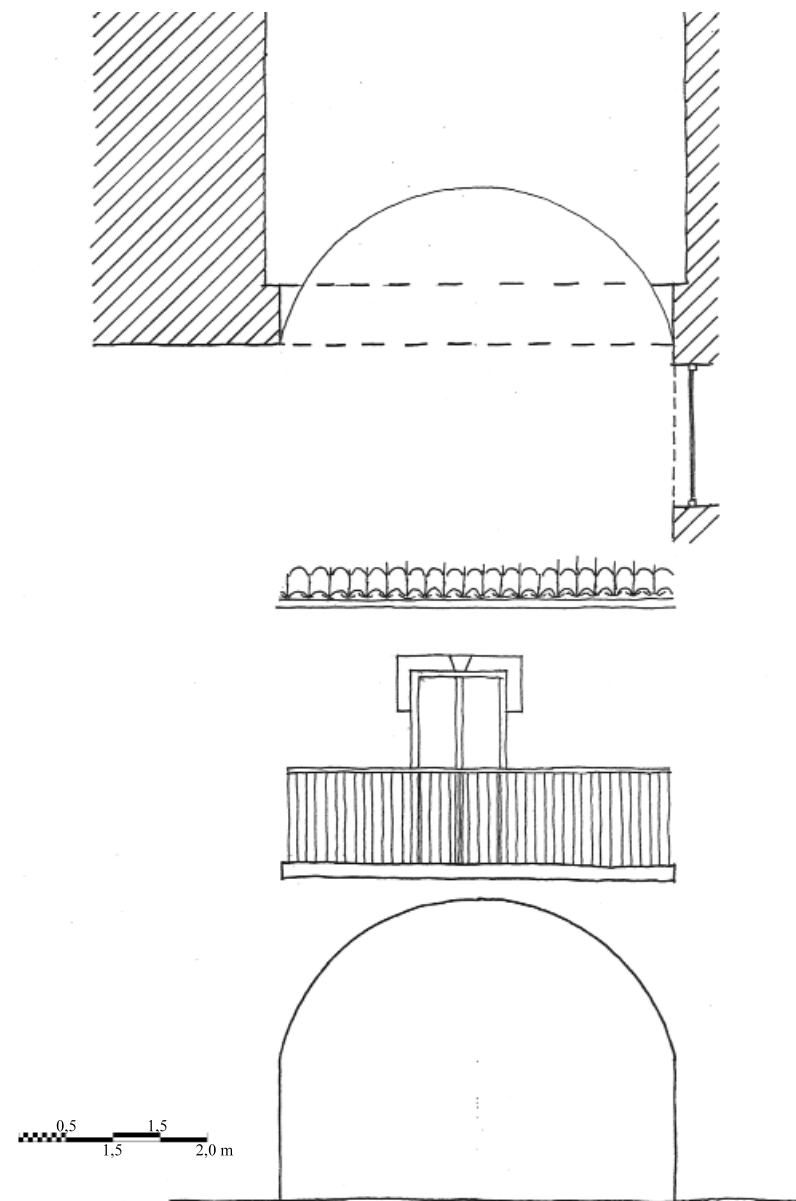

420 X 320

ARCO, PIAZZA UMBERTO I

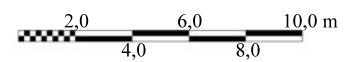
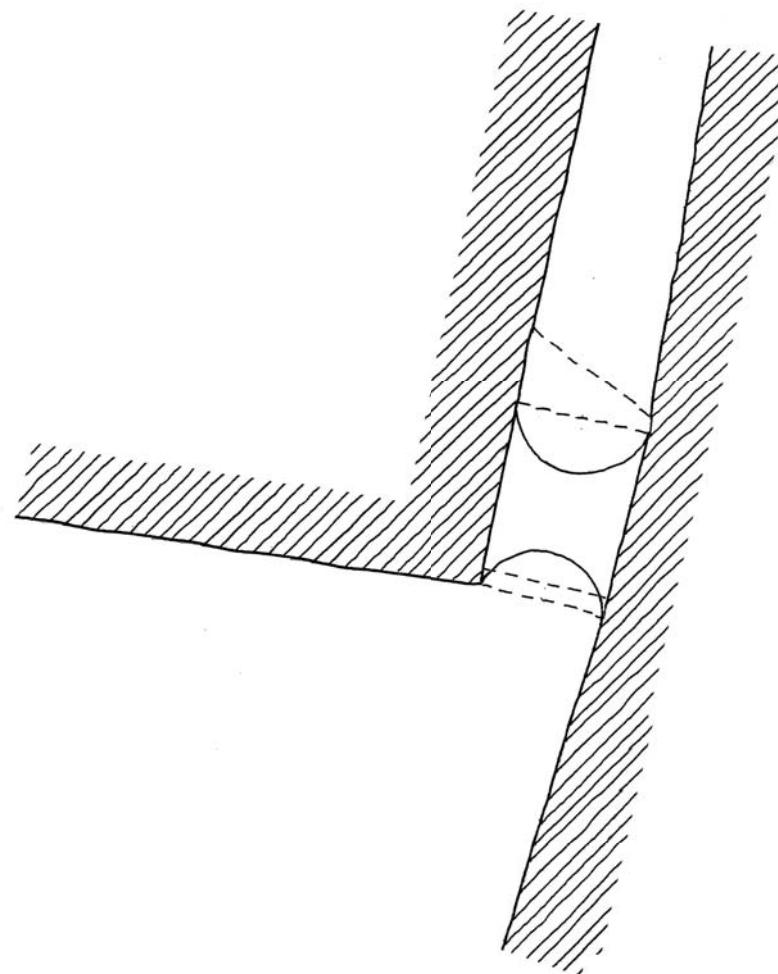

420 X 320

ARCO, PIAZZA UMBERTO I



ARCO
VIA DELLA PREPOSITURA

ARCO CIANCONE

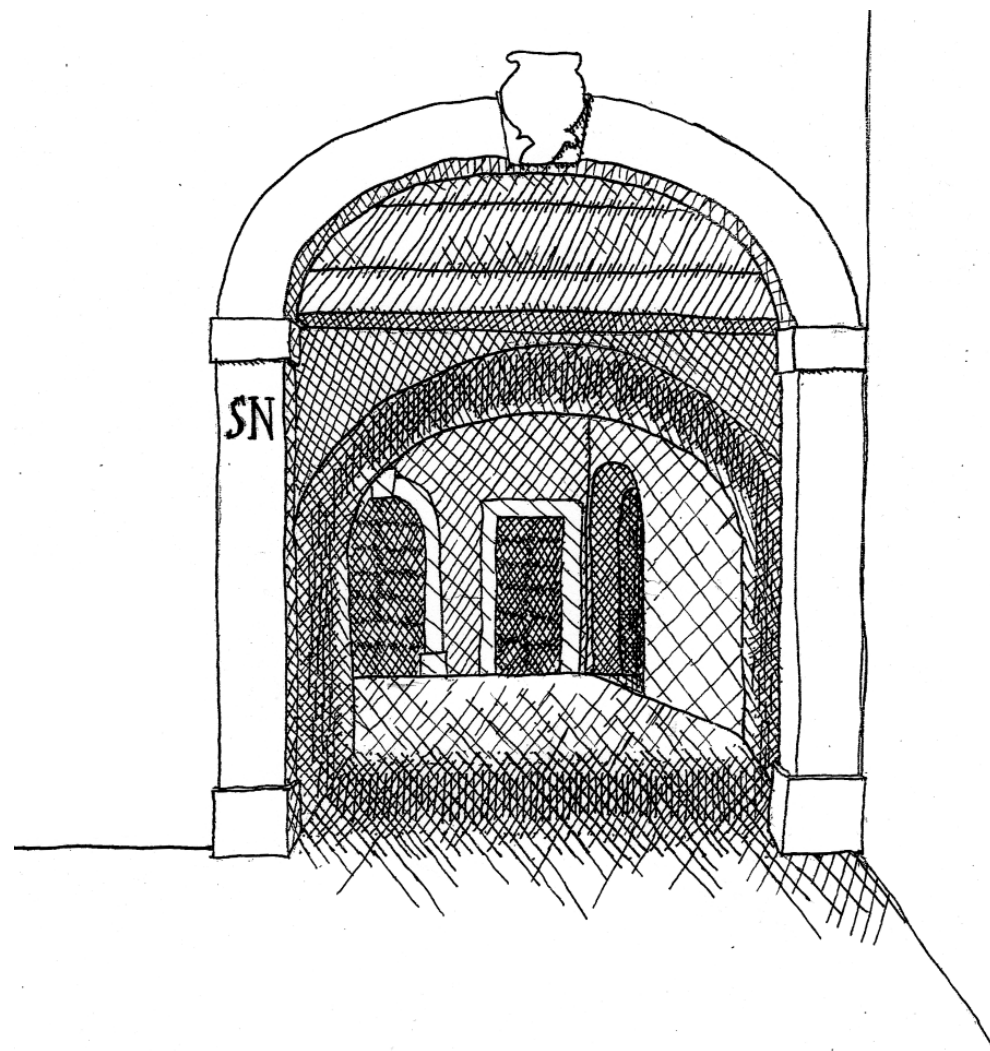

277 X 262

ARCO, VIA DELLA PREPOSITURA

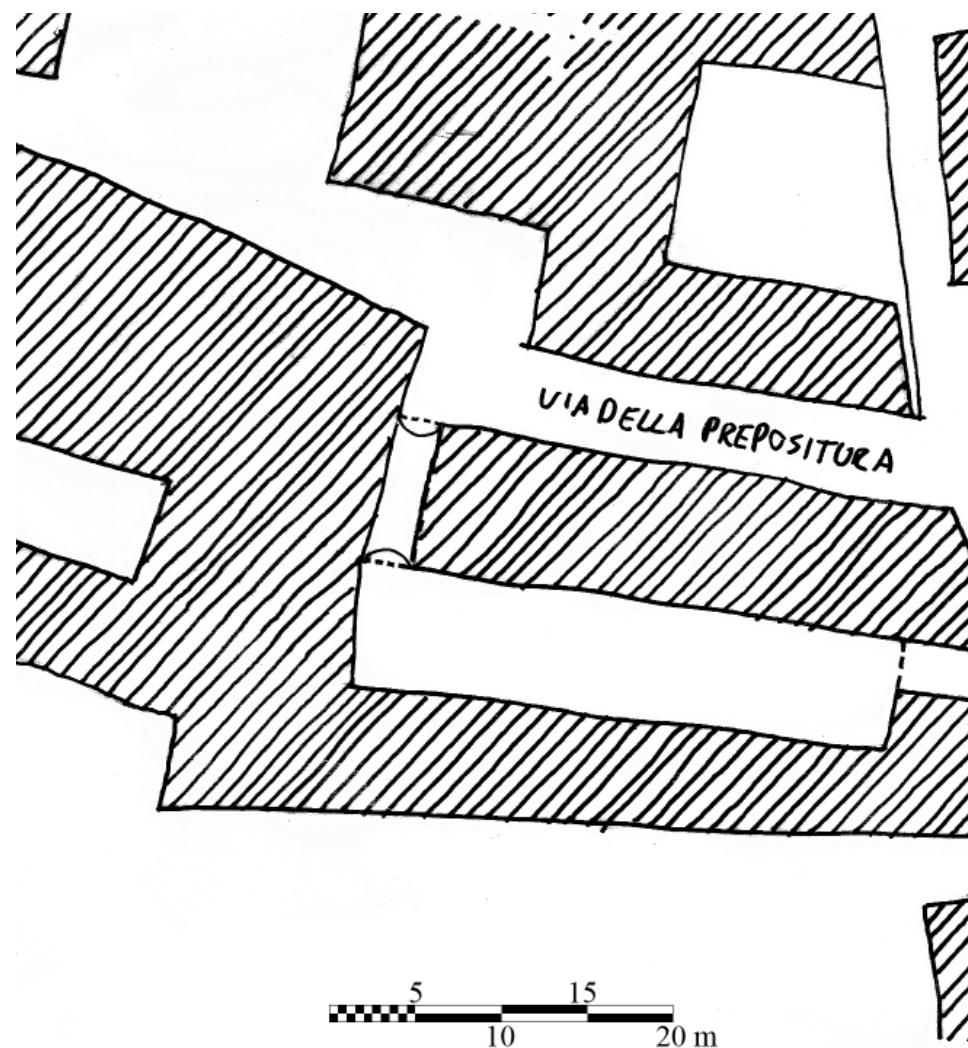

277 X 262

ARCO, VIA DELLA PREPOSITURA

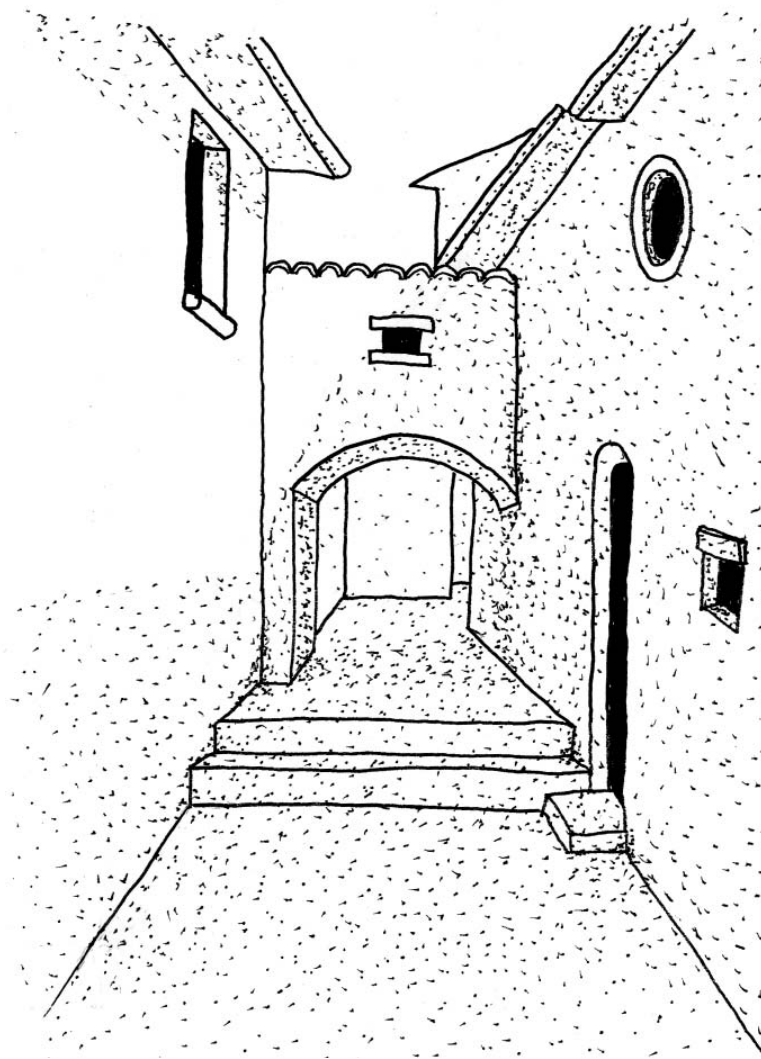

ARCO, VIA DELLA COLONNA

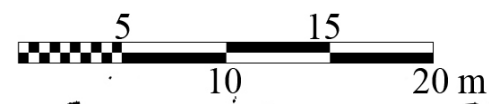
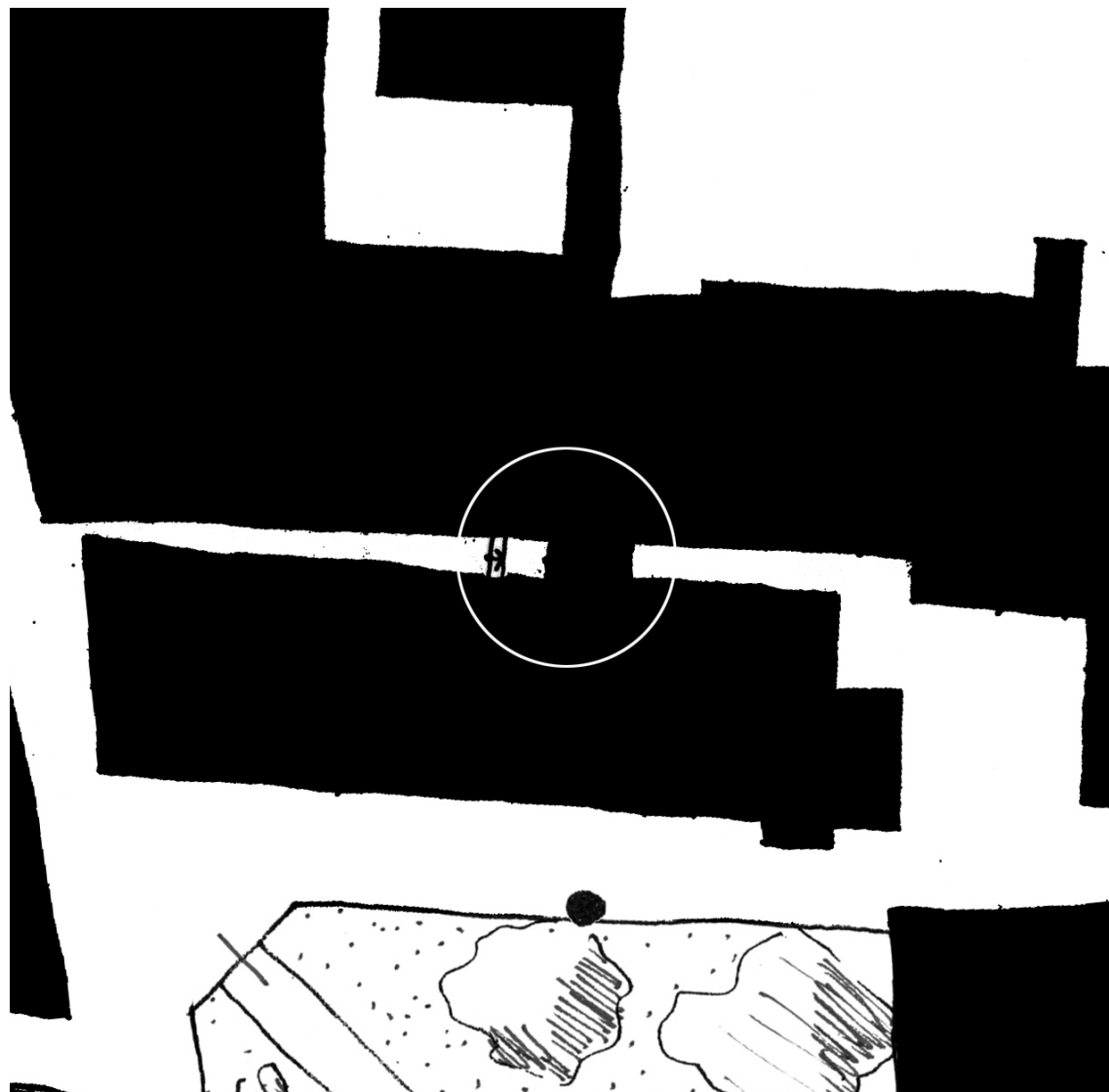

ARCO, VIA DELLA COLONNA



PORTONE, PROPRIETÀ MARCO CARPINI

PORTALE, CASA P. 310



PORTALE, PIAZZA UMBERTO I

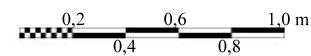
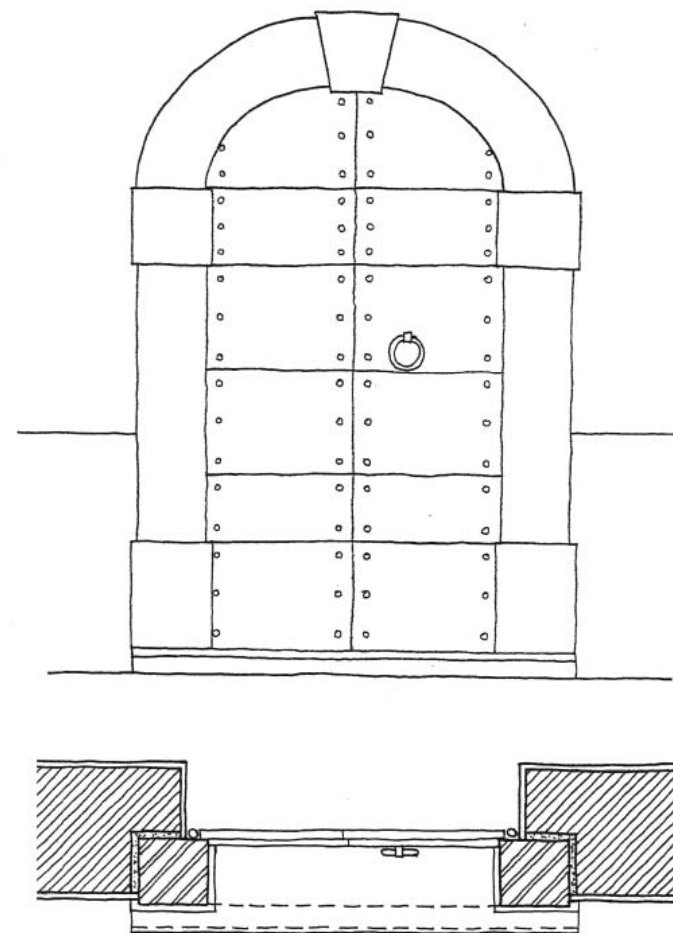

110 X 212

PORTONE, VIA DEGLI OPPIETI

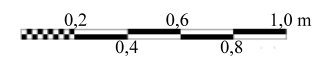
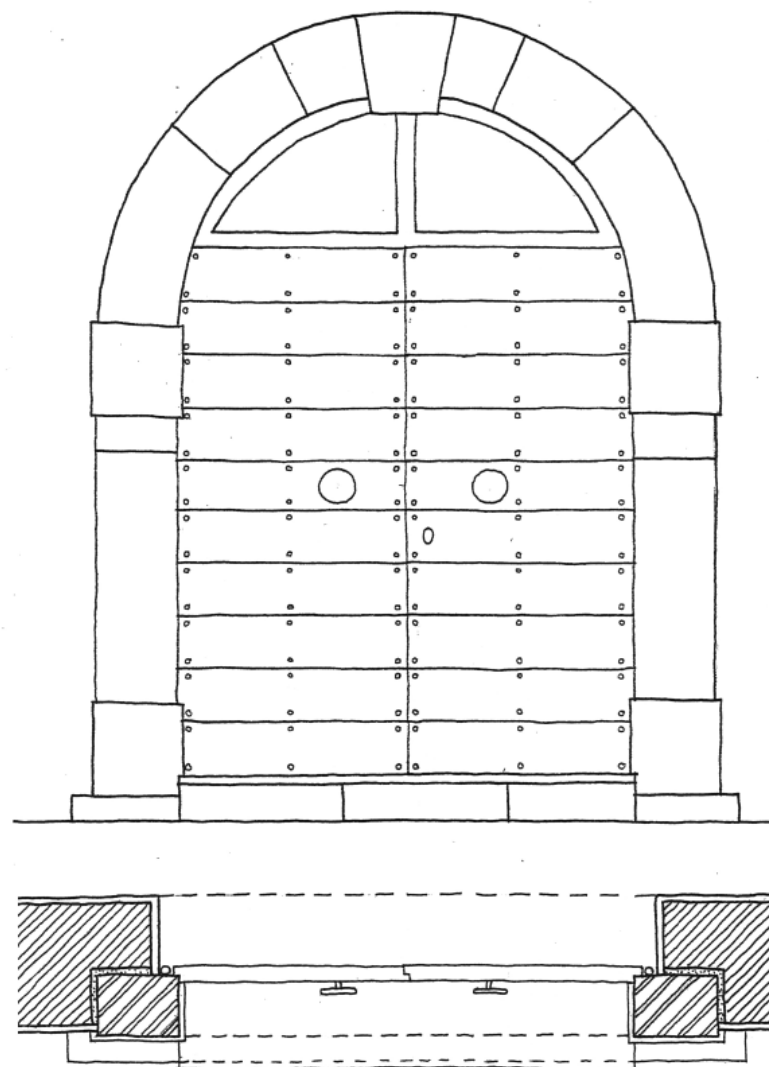

170 X 251

PORTONE, VIA DELLE MASSALE

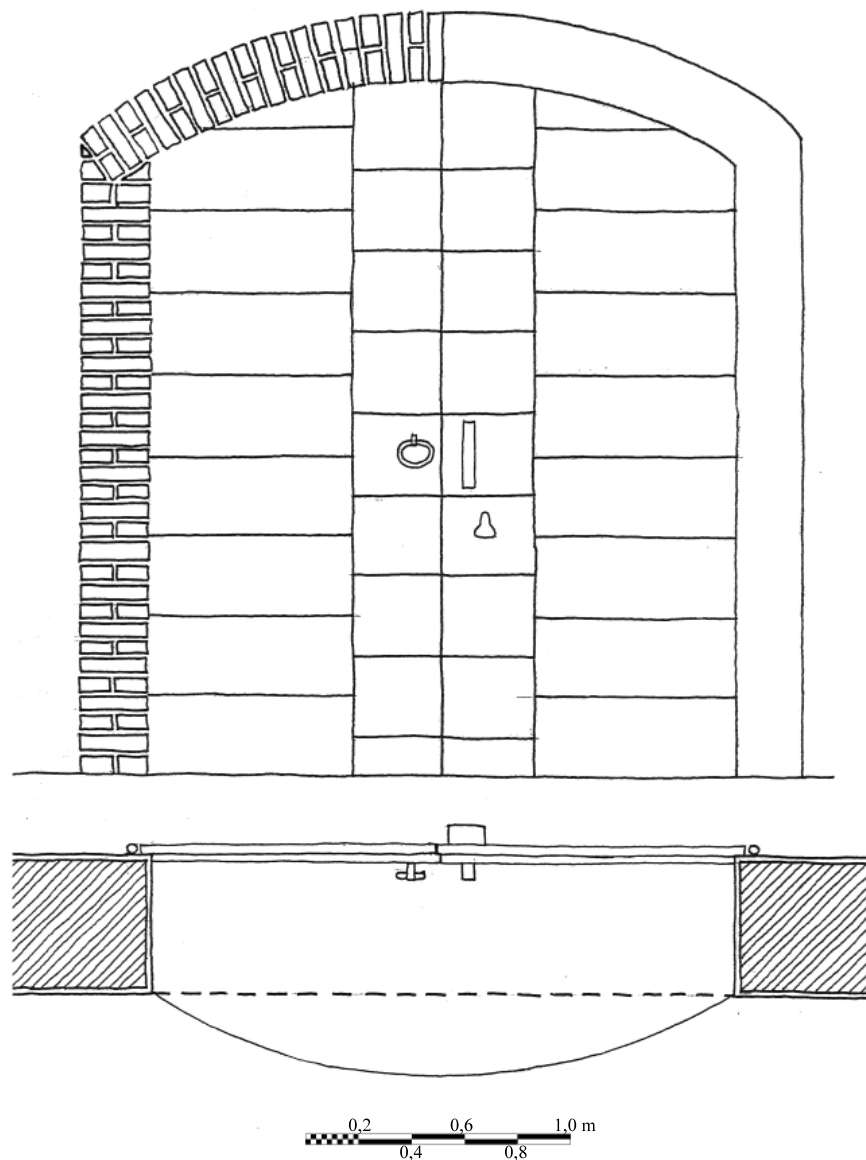

221 X 260

PORTONE, PROPRIETÀ MARCO CARPINI

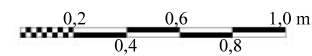
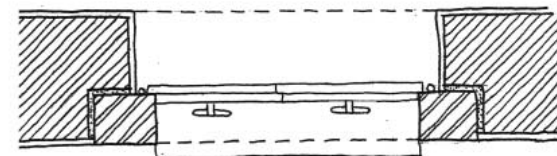
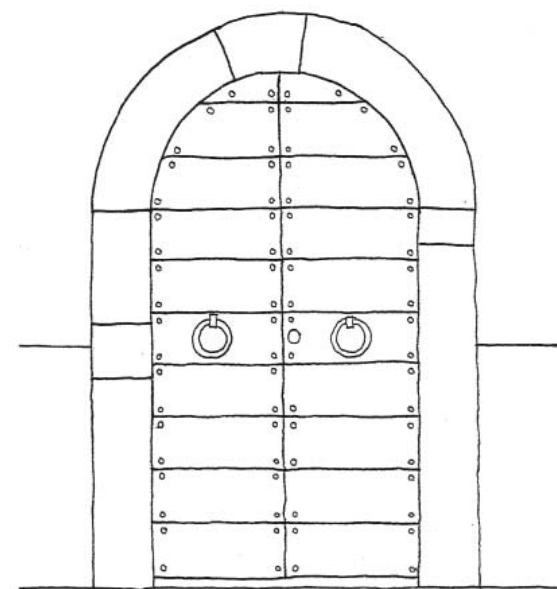

100 X 190

PORTONE, VIA DEGLI OPPIETI

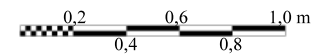
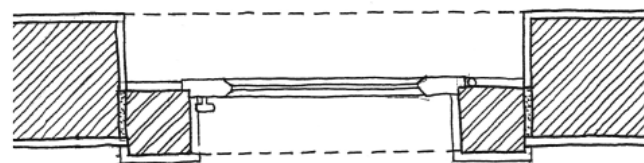
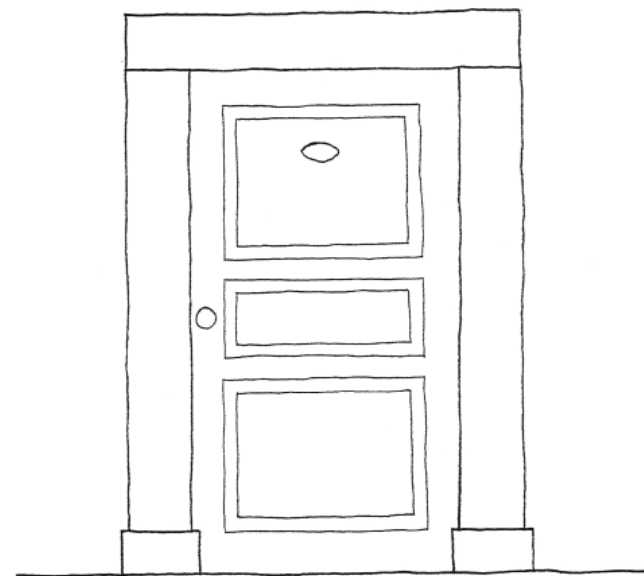

100 X 190

PORTONE, PIAZZA UMBERTO I

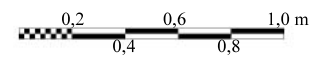
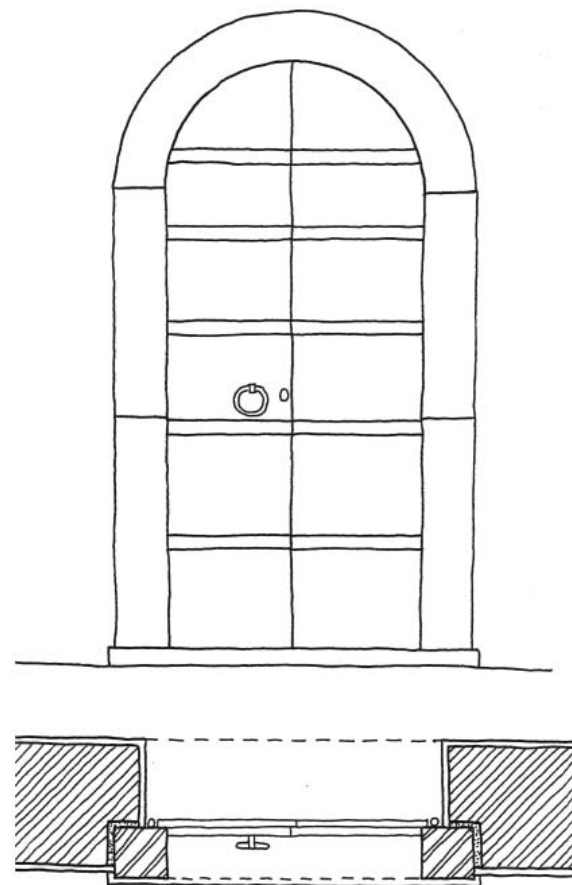

95 X 220

PORTONE, PIAZZA UMBERTO I

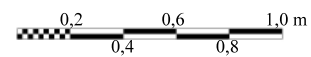
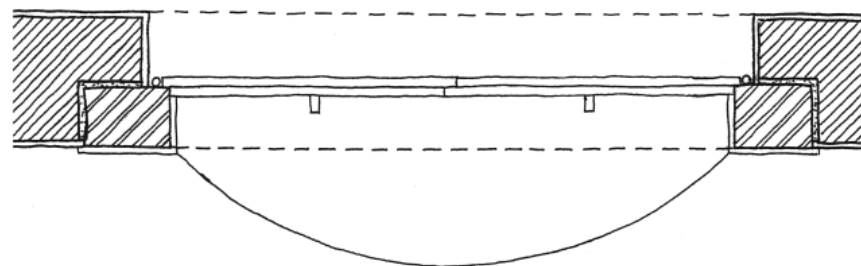
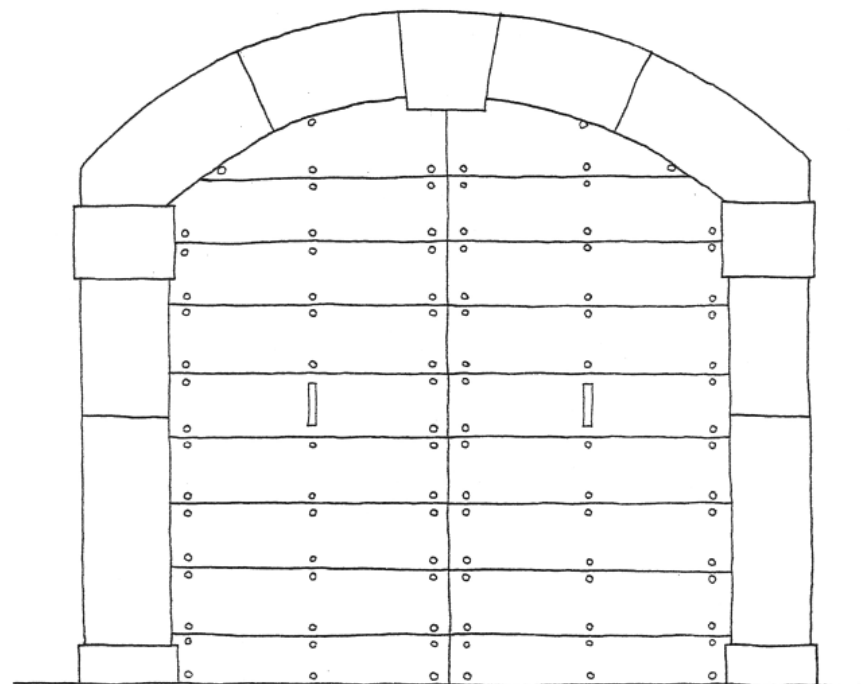

212 X 238

PORTONE, CASA P. 310

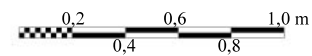
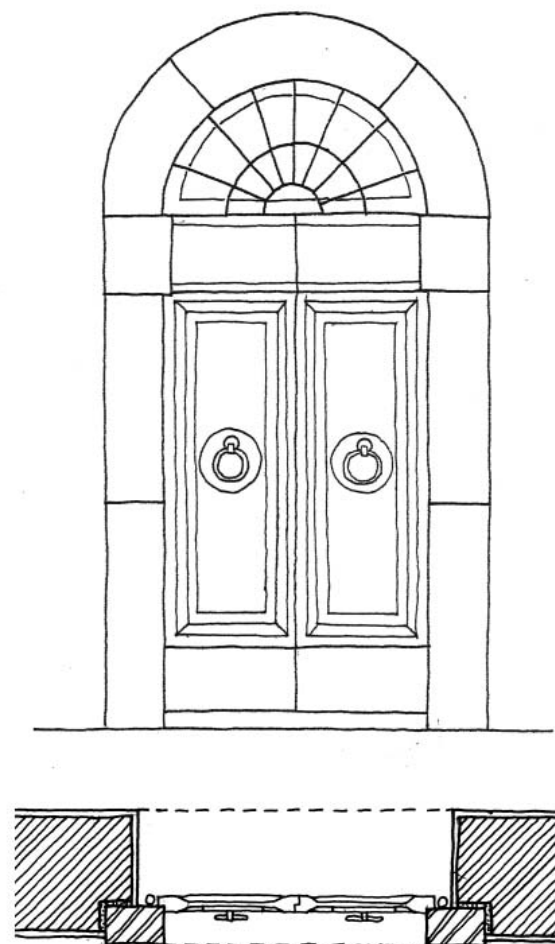

100 X 245

PORTONE, PIAZZA UMBERTO I



FINESTRE

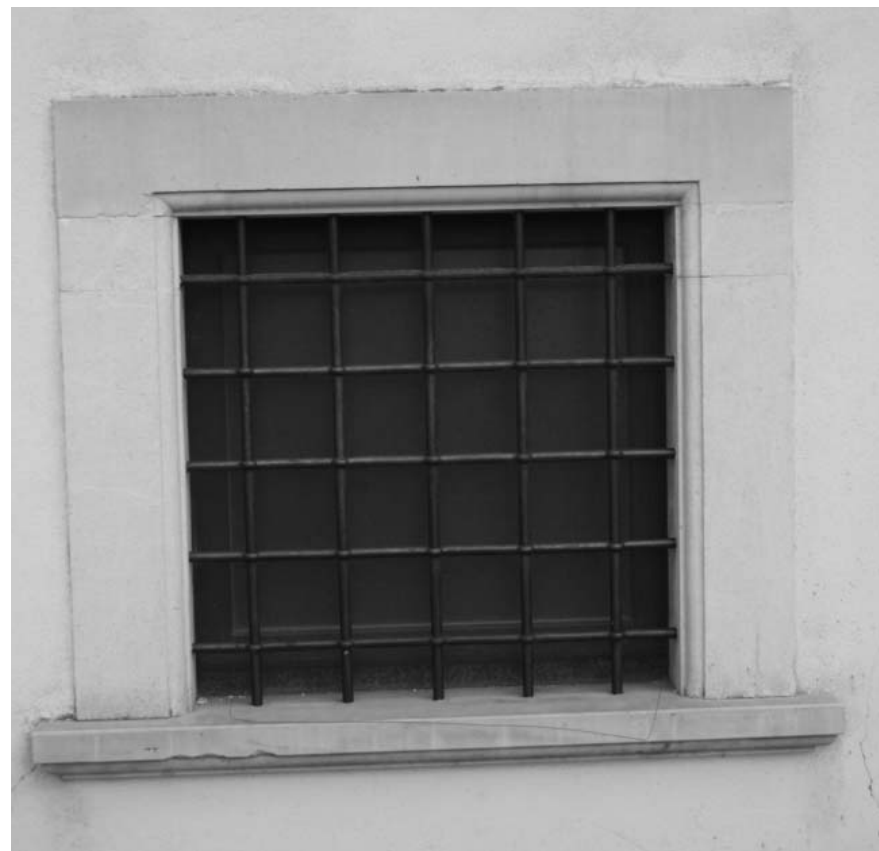

FINESTRA E APERTURA

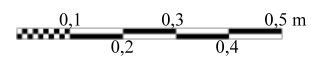
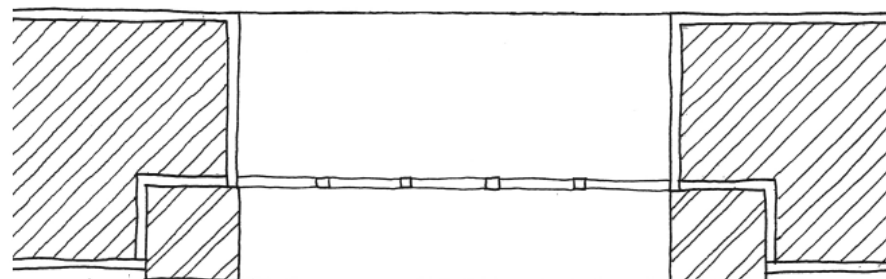
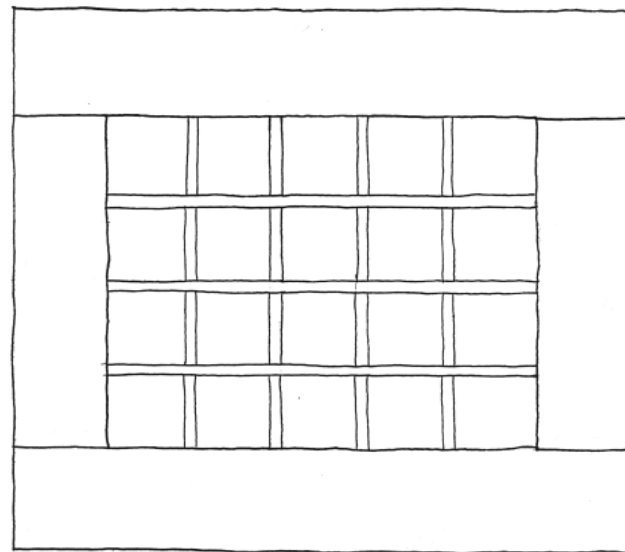

80 X 62

FINESTRA

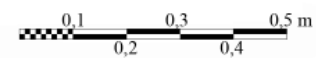
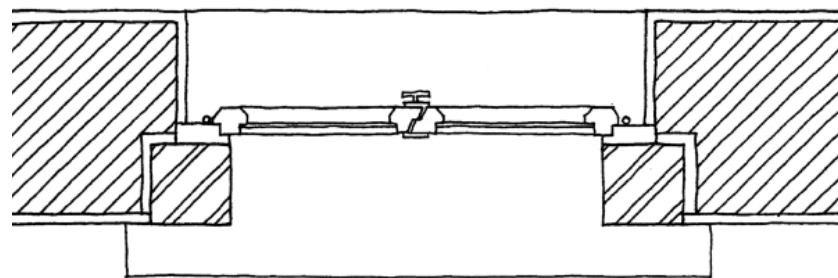
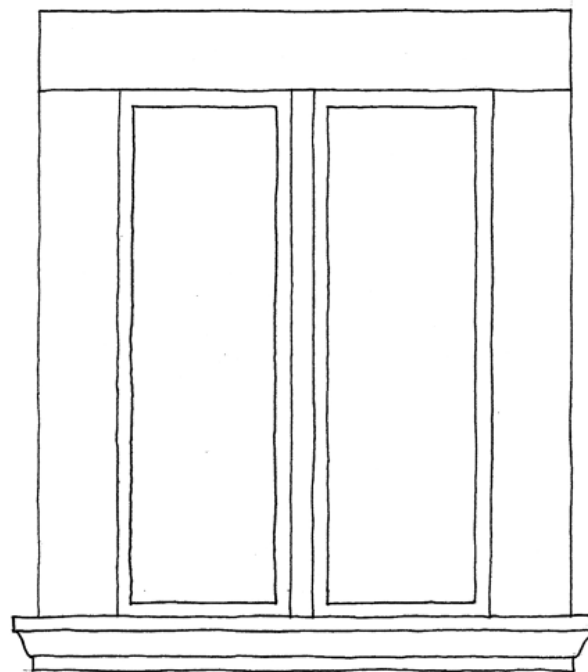

70 X 100

FINESTRA

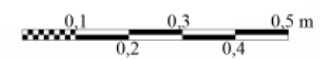
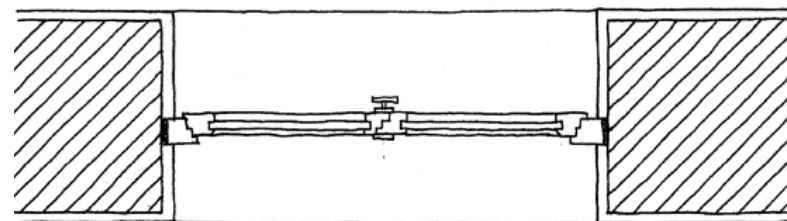
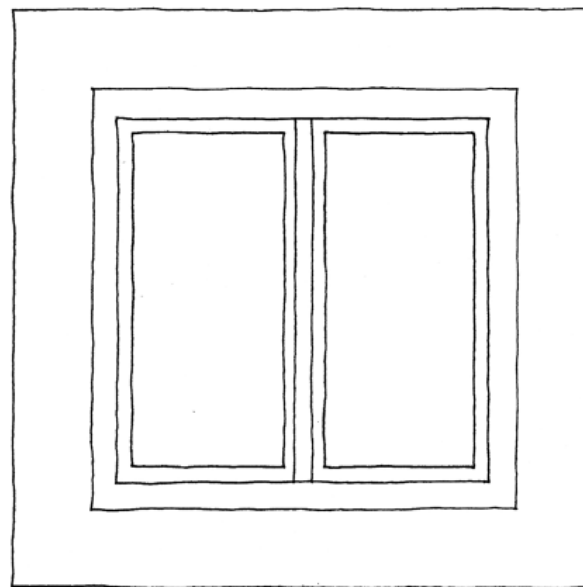

80 X 80

FINESTRA



PORTA FINESTRA

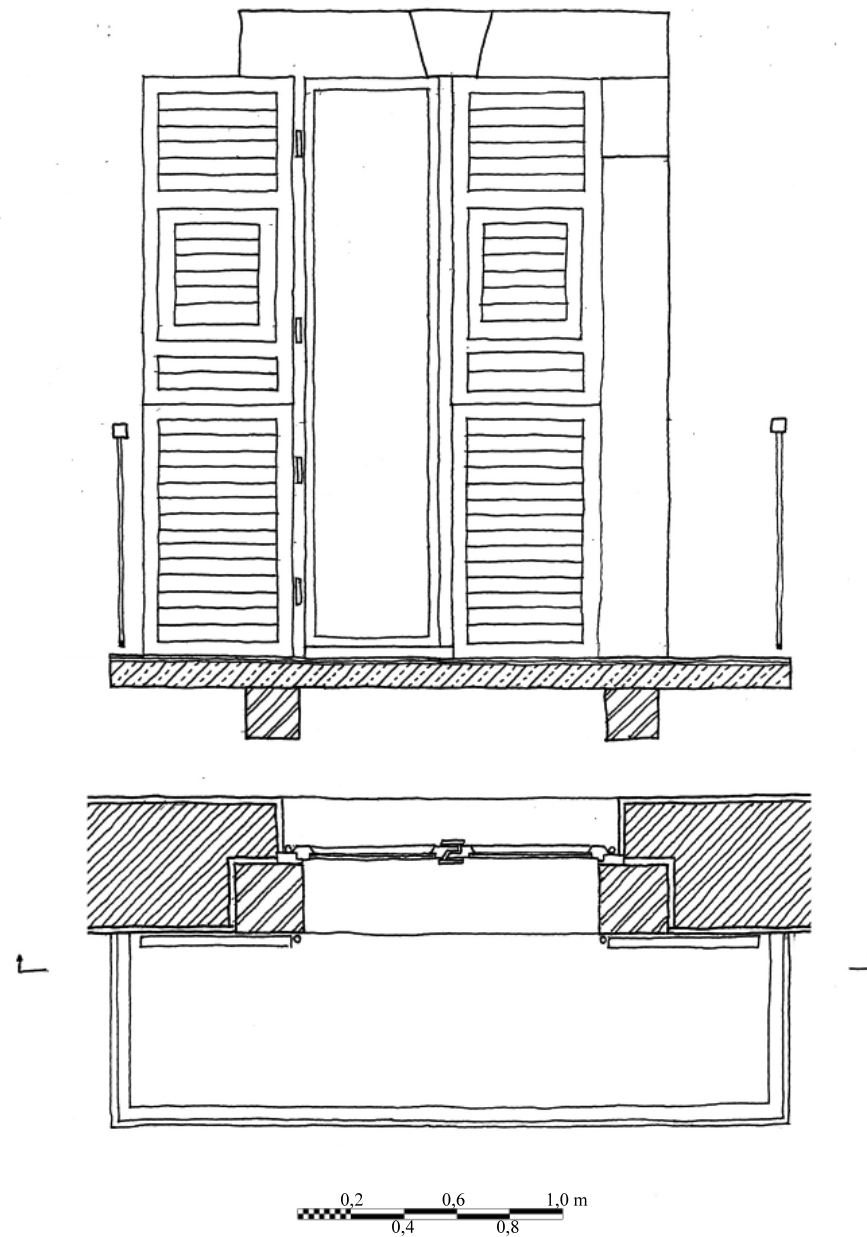

110 X 220

PORTA FINESTRA CON PERSIANE

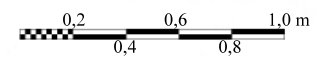
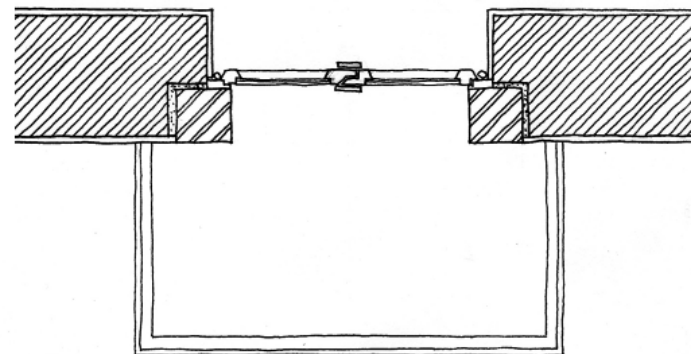
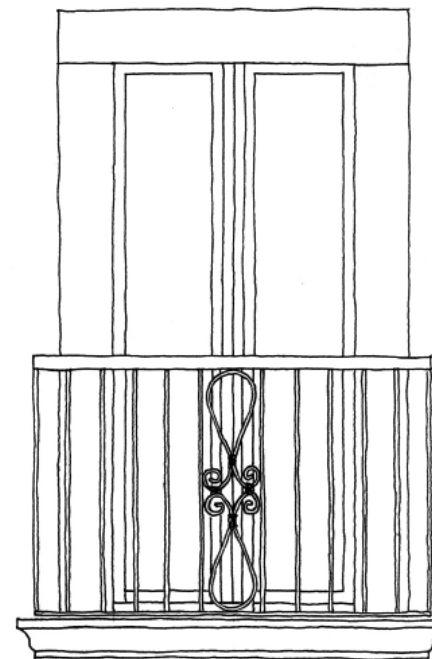

90 X 206

PORTA FINESTRA



SCALA ESTERNA, VIA DEL FORNO

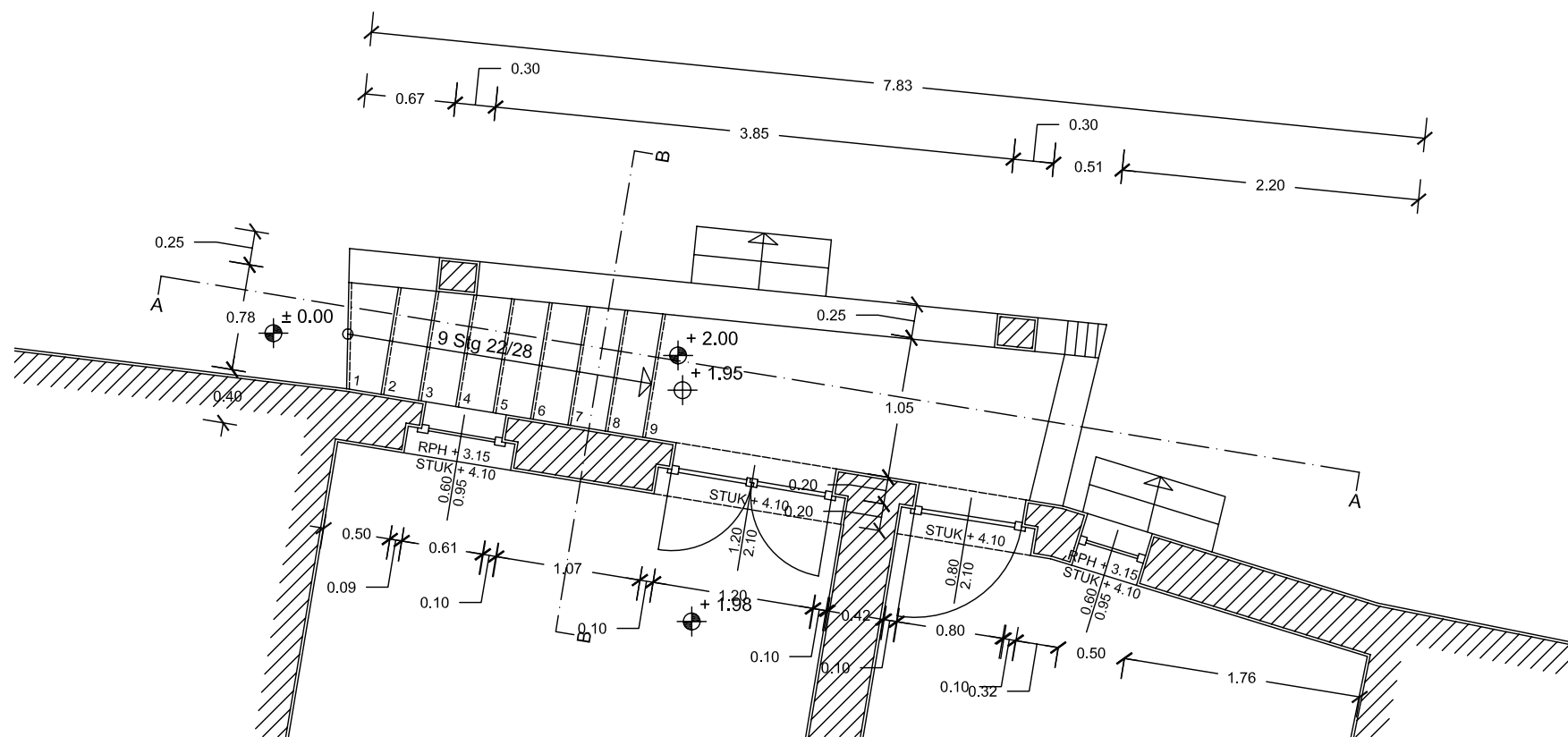

PIANTA E 1 - 1:50

SCALA ESTERNA, VIA DEL FORNO

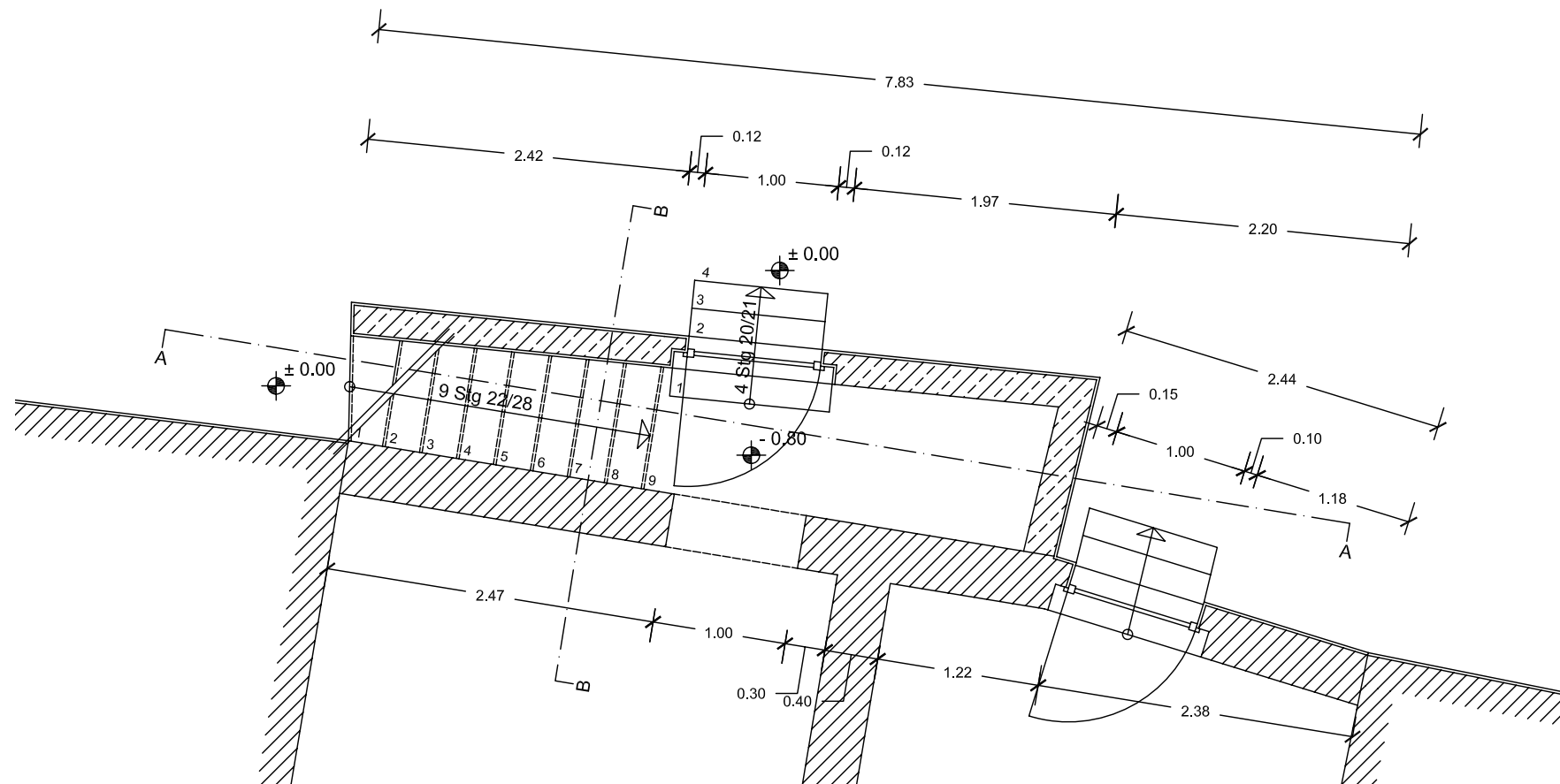

PIANTA E 0 - 1:50

SCALA ESTERNA, VIA DEL FORNO

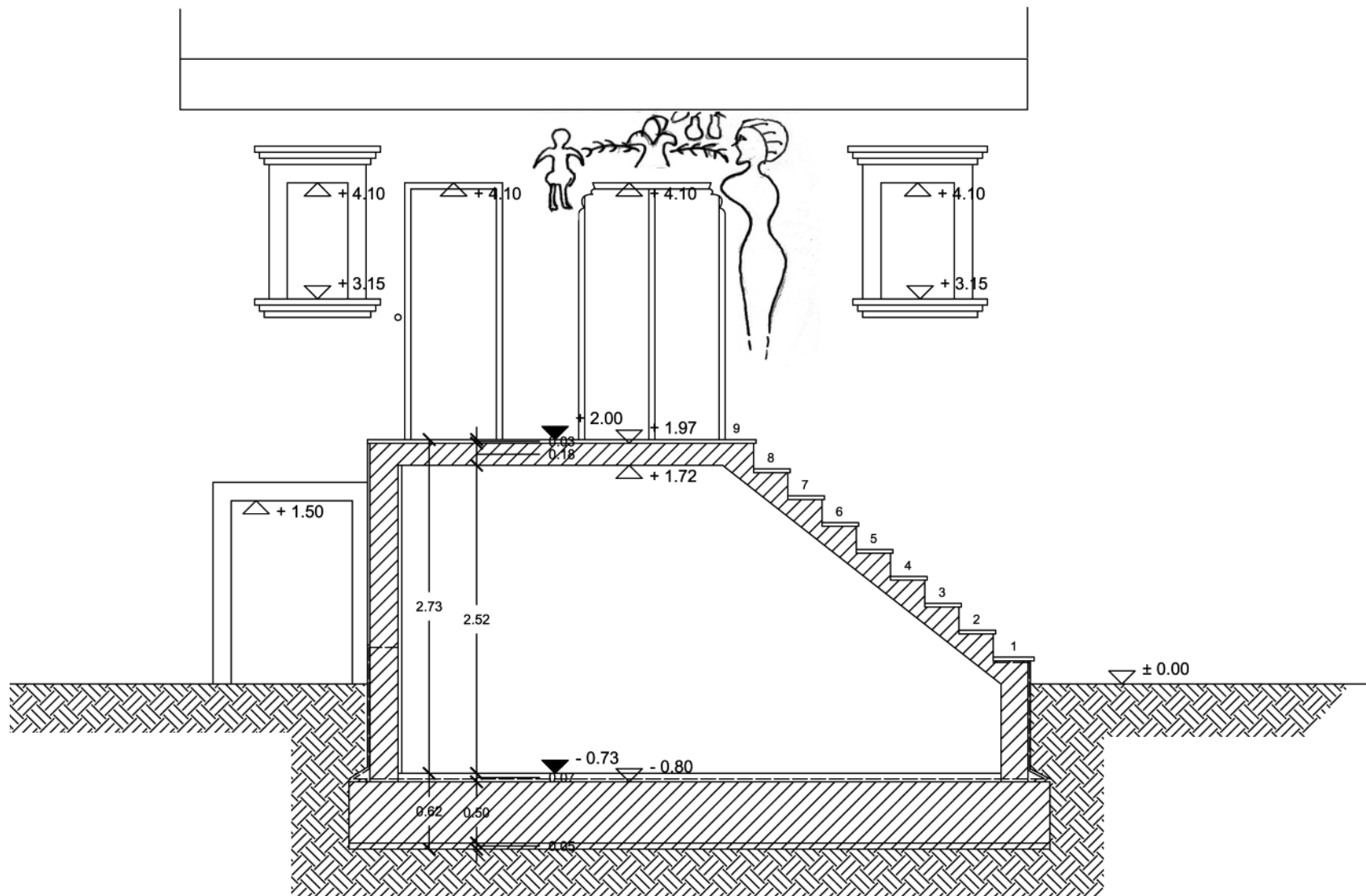

SEZIONE A-A - 1:50

SCALA ESTERNA, VIA DEL FORNO

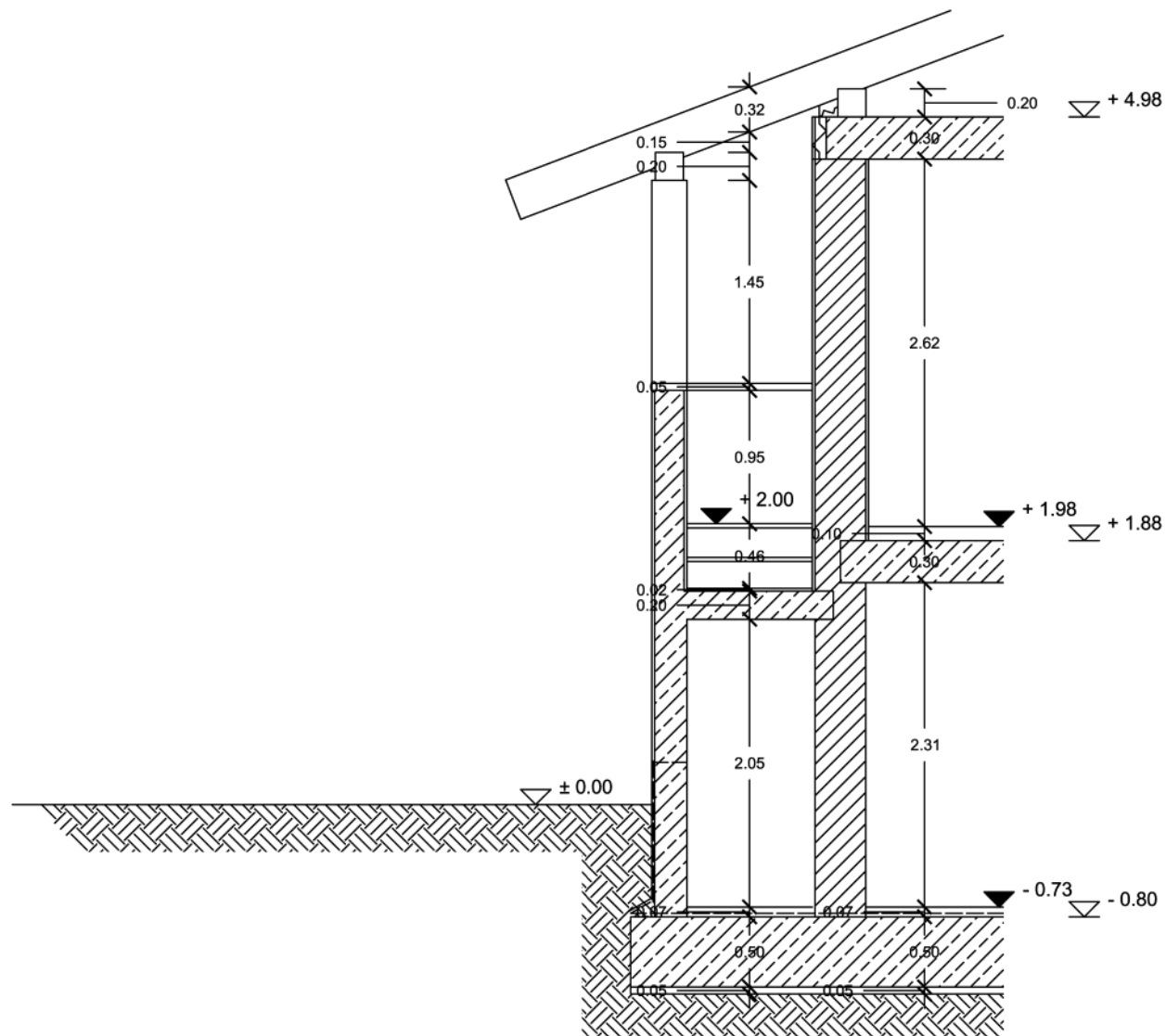

SEZIONE B-B - 1:50

SCALA ESTERNA, VIA DEL FORNO



STRUTTURA DEI TETTI

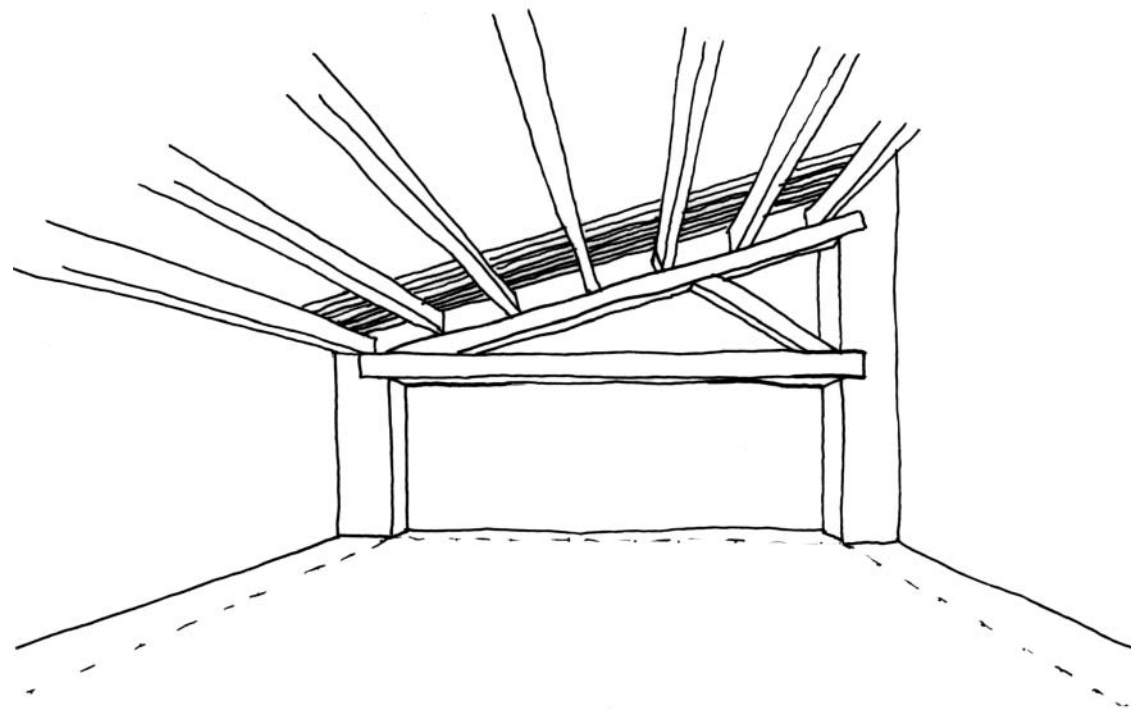

COSTRUZIONE TETTO IN LEGNO

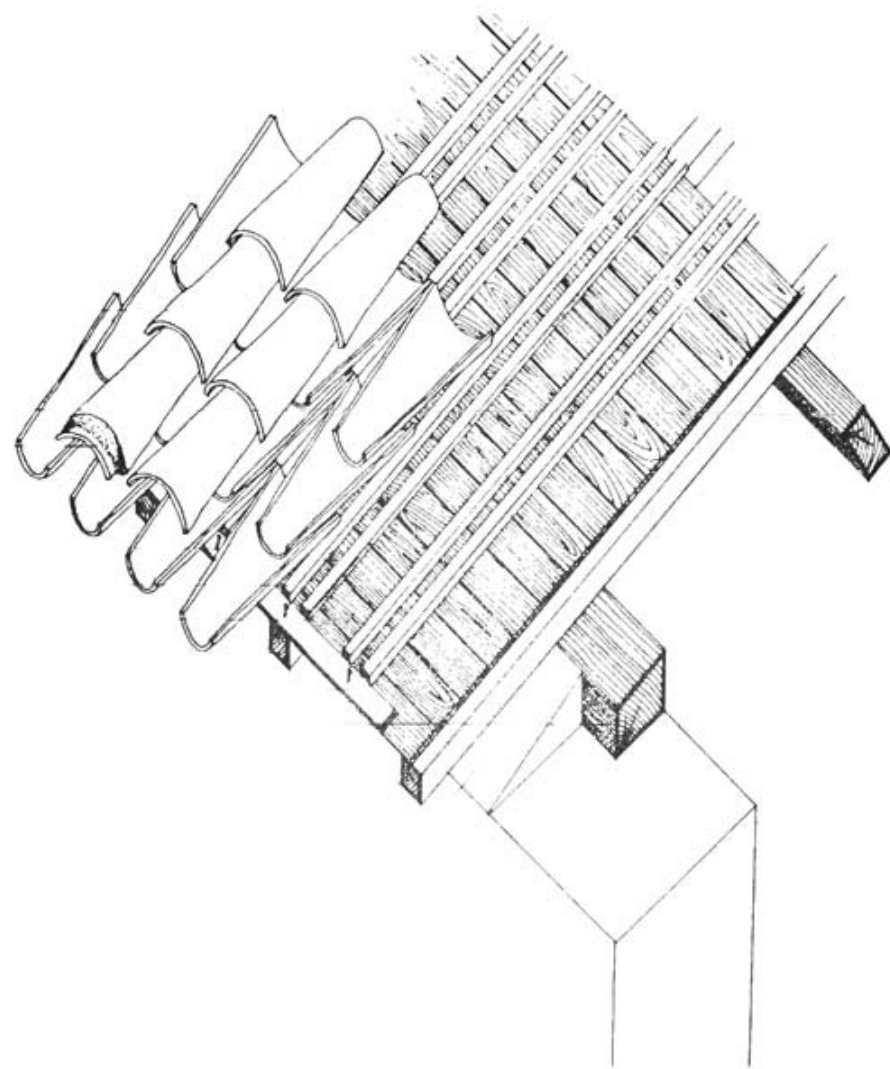

COPPI

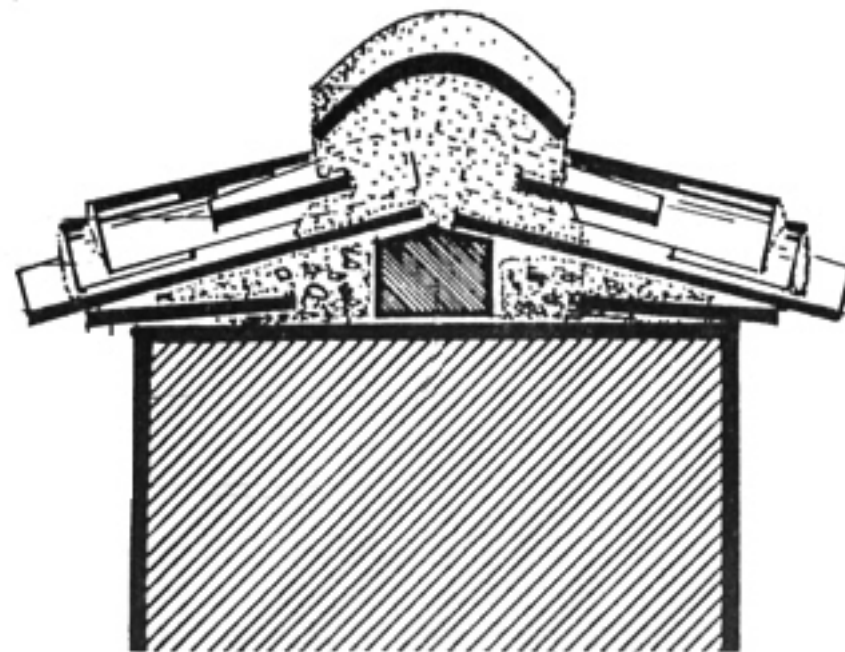

SEZIONE COPPI

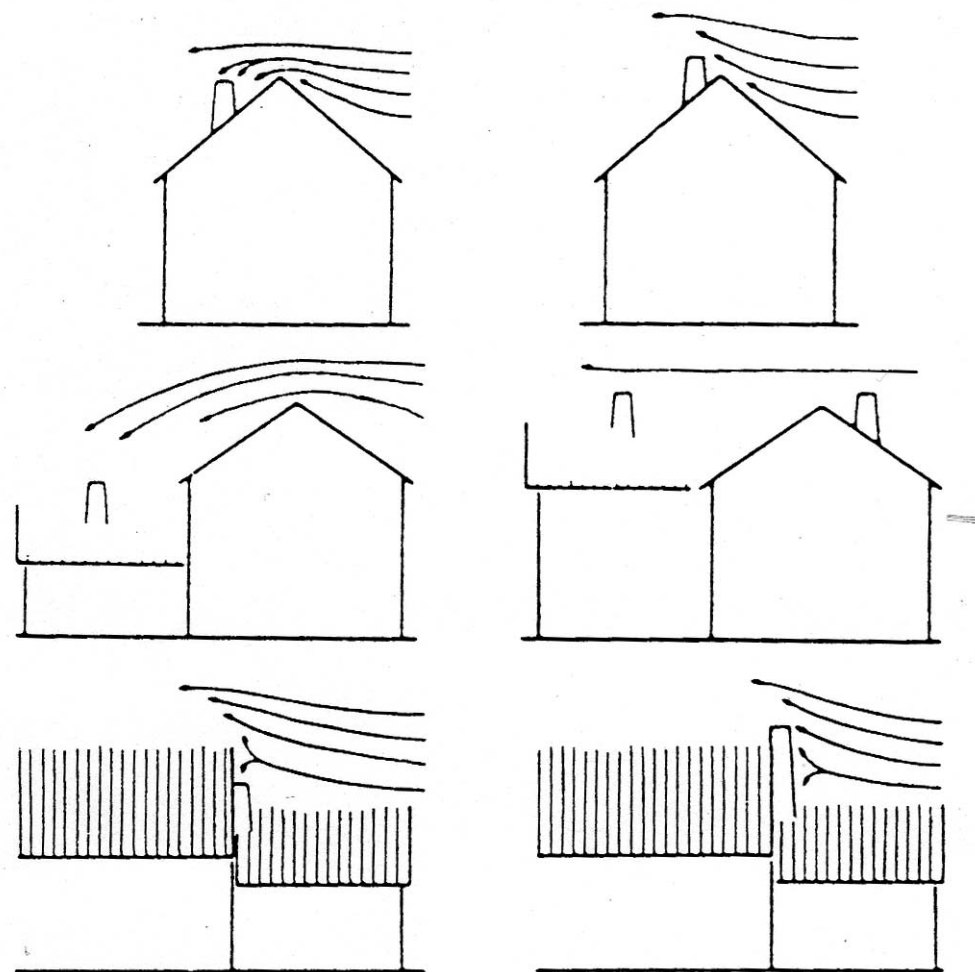

ERRATO

CORRETTO

POSIZIONAMENTO DEI CAMINI

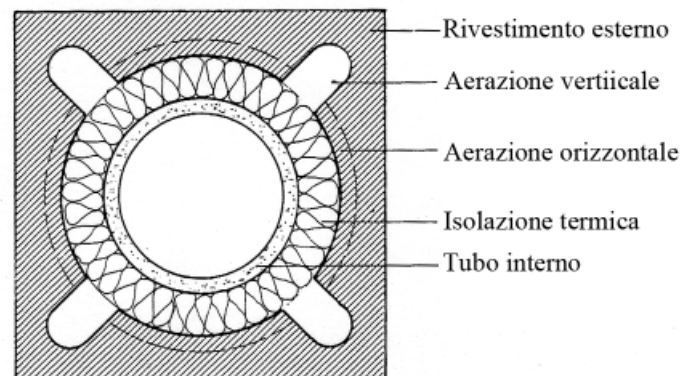
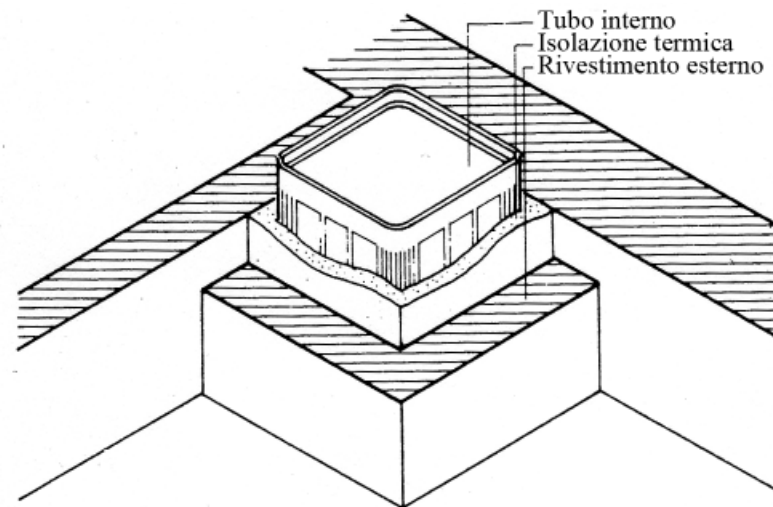

DETTAGLI COSTRUTTIVI, CAMINI



MURATURA ESTERNA

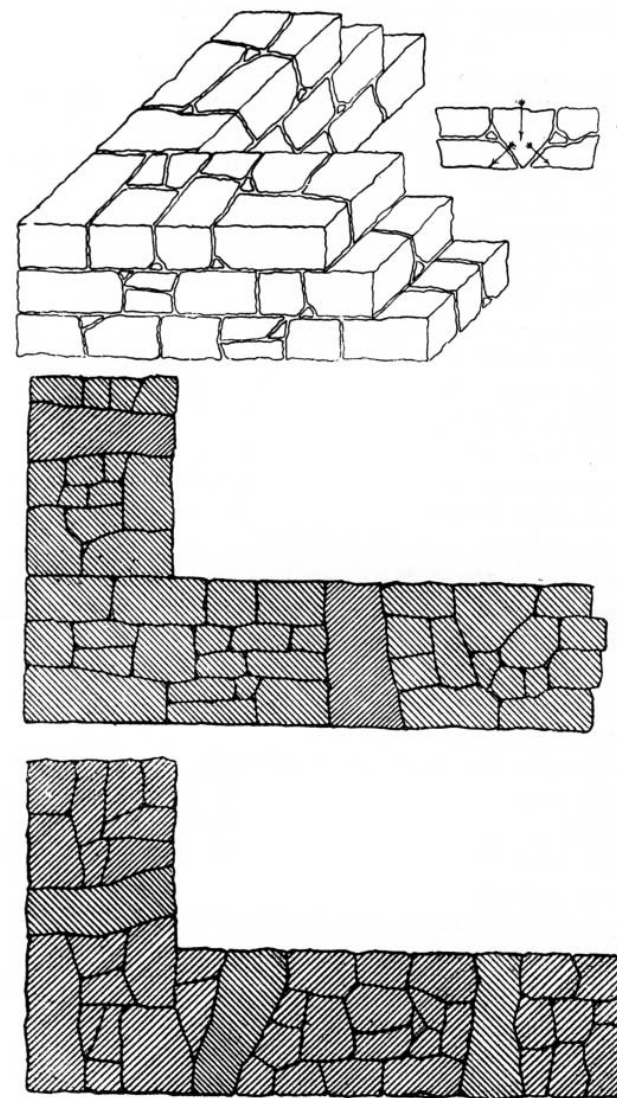

MURATURA AD OPERA INCERTA

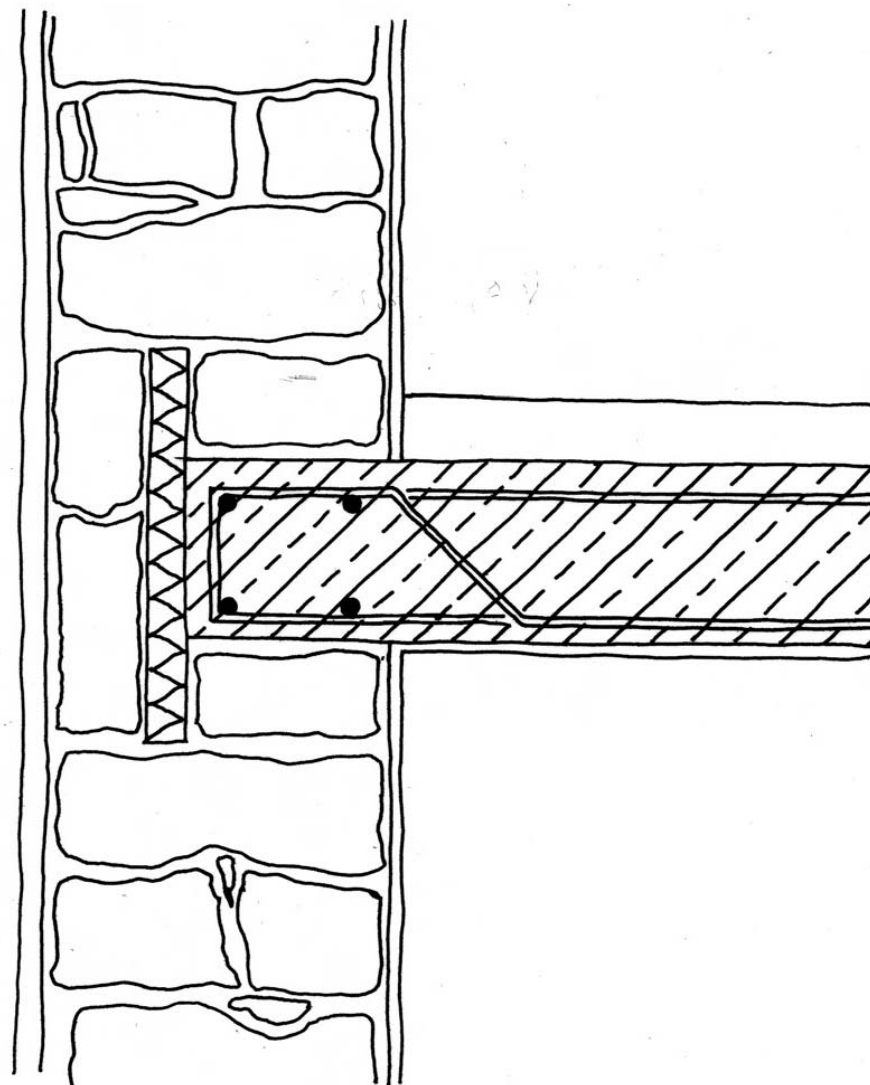

CORDOLO

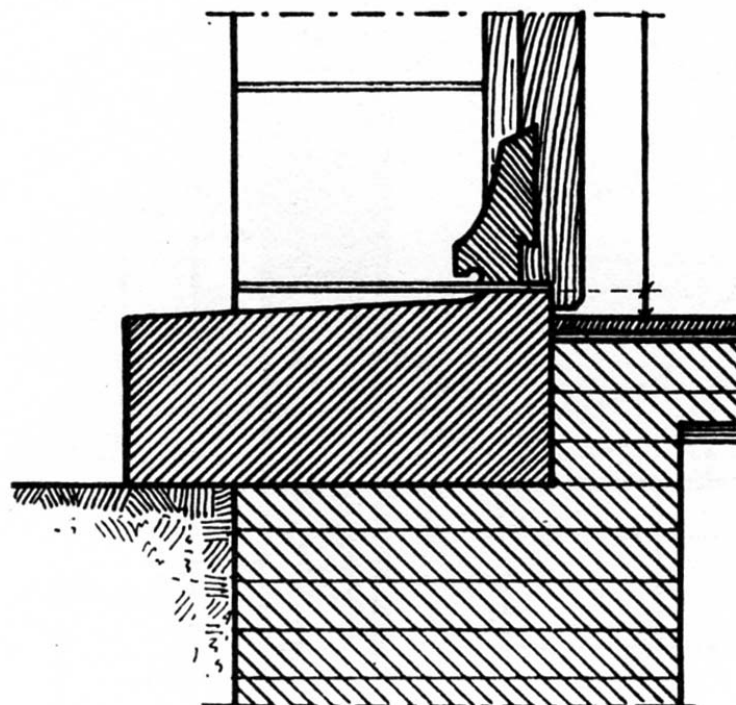

DETTAGLIO
SOGLIA



ONNA

DEPOSITO LAPIDEO



IL FORNO PUBBLICO DI MONTICCHIO
SIMILE AL FORNO DI ONNA



I GATTI DI ONNA

BIBLIOGRAFIA

- Senaud, Michel, Réhabilitation rurale, Fiches Techniques présentant le bâti régional, o.O. o.J.
 Barth, Othmar, Dörfliche Raumqualitäten im Überetsch – Kaltern, Innsbruck o. J.
 Architektenkammer Nordrhein-Westfalen (Hrsg.), Emil Steffan, Ausstellungskatalog der Kunsthalle Bielefeld, 1980
 Opderbecke, A./Wittenbecher, H., Der Steinmetz, Leipzig 1912
 Riccabona, Christof, Baukonstruktionslehre 1, Rohbauten, Wien 2004
 Pro Loco di Onna, Immagini di un paese, Onna 2005
 Pro Loco di Onna, Immagini di un paese II, Onna 2007
 Schmitt/Heinrich, Heene/Andreas, Hochbaukonstruktion, Die Bauteile und das Bauegefüge. Grundlagen des heutigen Bauens

INDICE IMMAGINI E DISEGNI

- Barlini, David/Beck ,Daniela/Fröis, Bea/Mitterer, Wittfrida/Passler, Christina/Prem, Bernhard/Pisoni, Alessandro/Schöpf, Tobias: P. 2, 11, 12, 17, 18, 31d, 36, 37, 46, 47, 51, 65, 69, 70, 71
 Calendario di Onna: P. 27, 28, 31s
 Fröis, Bea: P. 1
 Hambrusch, Horst: P. 7
 Lochmann, Martin: P. 5, 6, 8, 13, 14, 15, 16, 19, 20, 21, 22, 23, 24, 25, 26, 29, 30, 32, 33, 34, 35, 38, 39, 40, 41, 42, 43, 44, 45, 48, 49, 50, 52, 53, 54, 55, 56, 57, 58, 60 (secondo Senaud), 67 (secondo Riccabona 2004)
 Opderbecke, A./Wittenbecher, H., Der Steinmetz, Leipzig 1912: P. 66, 68
 Senaud, Michel, Réhabilitation rurale, Fiches Techniques présentant le bâti régional, o.O. o.J.: P. 61, 62
 Schmitt/Heinrich, Heene/Andreas, Hochbaukonstruktion, Die Bauteile und das Bauegefüge. Grundlagen des heutigen Bauens: P. 63, 64
 www.bing.com/maps/: P. 9, 10, 59